

No. 4789. AGREEMENT CONCERNING THE ADOPTION OF UNIFORM CONDITIONS OF APPROVAL AND RECIPROCAL RECOGNITION OF APPROVAL FOR MOTOR VEHICLE EQUIPMENT AND PARTS. DONE AT GENEVA ON 20 MARCH 1958 ¹

ENTRY INTO FORCE of Regulation No. 20 [Uniform provisions concerning the approval of motor vehicle headlights emitting an asymmetrical passing beam or a driving beam or both and equipped with halogen lamps (H₄ lamps) and of the lamps themselves] as an annex to the above-mentioned Agreement.

The said Regulation came into force on 1 May 1971 in respect of Belgium and the Netherlands, in accordance with article 1(5) of the Agreement.

Authentic texts of the Regulation: English and French.

Registered ex officio on 1 May 1971.

A. ADMINISTRATIVE PROVISIONS

1. *Definition of "type"*

Headlights or lamps of different "types" means headlights or lamps which differ in such essential respects as:

- 1.1. for *headlights*:
 - 1.1.1. the trade name or mark;
 - 1.1.2. the characteristics of the optical system;
 - 1.1.3. the inclusion or elimination of components capable of altering the optical effects by reflection, refraction or absorption; the fitting or elimination of filters intended solely to change the colour of the beam but not its light distribution does not entail a change of type;
 - 1.1.4. suitability for right-hand or left-hand traffic or for both traffic systems;
 - 1.1.5. the kind of beam produced (passing beam, driving beam or both);

¹ United Nations, *Treaty Series*, vol. 335, p. 211; for subsequent actions, see references in Cumulative Indexes Nos. 4 to 8, as well as annex A in volumes 601, 606, 607, 609, 630, 631, 652, 656, 659, 667, 669, 672, 673, 680, 683, 686, 696, 723, 730, 740, 752, 754, 756, 759, 764, 768, 771 and 772.

- 1.2. for *lamps*:
 - 1.2.1. the trade name or mark;
 - 1.2.2. the rated voltage;
 - 1.2.3. the shape of the filament or filaments;
 - 1.2.4. the design of the bulb and its effect on the optical results;
 - 1.2.5. the inclusion or elimination of components capable of altering the optical effects by reflection, refraction or absorption: if the lamp has a built-in yellow filter, the presence or absence of this filter does not constitute a change of type, provided that the filter is tested in accordance with paragraph 14. below.
2. *Application for approval*
 - 2.1. The application for approval shall be submitted by the holder of the trade name or mark or by his duly accredited representative. If the application is for approval of a headlight it shall specify:
 - 2.1.1. whether the headlight is intended to provide both a passing beam and a driving beam or only one of these beams;
 - 2.1.2. whether, if the headlight is intended to provide a passing beam, it is designed for both left-hand and right-hand traffic or for either left-hand or right-hand traffic only.
 - 2.2. Every application for approval shall be accompanied by:
 - 2.2.1. drawings in triplicate, sufficiently detailed to permit identification of the type (see paragraphs 3.2. and 4.2.) and showing:
 - 2.2.1.1. for approval of a headlight, the headlight in cross (vertical) section and in front elevation, with details of the flutings, if any, of the glass;
 - 2.2.1.2. for approval of a lamp, front and side views of the lamp;
 - 2.2.2. a brief technical description;
 - 2.2.3. samples, as follows:
 - 2.2.3.1. for approval of a headlight: two samples;
 - 2.2.3.2. for approval of a lamp: five samples;
 - 2.2.3.3. for the testing of a coloured filter or coloured screen (or of a coloured glass): two samples.

- 2.2.4. In the case of a type of lamp differing only by the trade name or mark from a type which has already been approved, it shall be sufficient to submit a declaration that the type submitted is identical (except for its trade name or mark) with the type already approved, identified by its approval number, and has been produced by the same manufacturer. This procedure may, however, be used only where the applicant for the further approval is the holder of both of the trade names or marks.

3. *Markings* *

- 3.1. Headlights and lamps submitted for approval shall bear the trade name or mark of the applicant; this mark must be clearly legible and indelible.
- 3.2. A space of sufficient size to accommodate the approval mark shall be provided on every lamp; a space of sufficient size to accommodate the approval mark and the additional symbols provided for in paragraph 4.3.2. below shall be provided both on the glass and on the main body ** of every headlight; these spaces shall be shown on the drawings referred to in paragraph 2.2.1. above.
- 3.3. Headlights designed to satisfy the requirements both of right-hand and of left-hand traffic shall bear markings indicating the two settings of the optical unit on the vehicle or of the lamp on the reflector; these markings shall consist of the letters "R/D" for the position for right-hand traffic and the letters "L/G" for the position for left-hand traffic.

4. *Approval*

- 4.1. If all the samples of a type of headlight or lamp which are submitted in accordance with paragraph 2.2.3. above meet the requirements of this Regulation, approval shall be granted.
- 4.2. An approval number shall be assigned to each type approved; the number so assigned shall not be assigned by the same Contracting Party to another

* In the case of headlights designed to meet the requirements of traffic moving on one side of the road only (either right or left), it is further recommended that the area which can be occulted to prevent discomfort to users in a country where traffic moves on the side of the road opposite to that of the country for which the headlight was designed should be outlined indelibly on the front glass. This marking is not necessary, however, where the area is clearly apparent from the design.

** If the glass cannot be separated from the main body, the provision of such a space on the glass will suffice.

type of headlight or lamp covered by this Regulation. * Notice of approval or of refusal of approval of a type of headlight or lamp shall be communicated to the countries Parties to the Agreement which apply this Regulation by means of a form conforming to model A in annex 1 to this Regulation in the case of a headlight and to model B in that annex in the case of a lamp, and of an attached drawing (supplied by the applicant for approval) in a format not larger than A 4 (210×297 mm), or folded to that format on a scale of 2:1 for lamps and, if possible, 1:1 for headlights.

4.3. There shall be placed on every headlight and every lamp conforming to a type approved under this Regulation, in the spaces referred to in paragraph 3.2. above, in addition to the mark prescribed in paragraph 3.1:

4.3.1. an international approval mark ** consisting of:

4.3.1.1. a circle surrounding the letter " E " followed by the distinguishing number of the country which has granted approval; ***

4.3.1.2. the approval number placed below the circle on headlights and close to the circle on lamps;

4.3.2. the following additional symbol or symbols:

4.3.2.1. on headlights meeting left-hand traffic requirements only, a horizontal arrow placed under the circle, pointing to the right of an observer facing the headlight, i.e. to the side of the road on which traffic moves;

4.3.2.2. on headlights designed to meet the requirements of both traffic systems by means of an appropriate adjustment of the setting of the optical unit or the lamp, a horizontal arrow with a head on each end, the heads pointing respectively to the left and to the right, placed under the approval number;

* A change in the colour of the beam or beams emitted by headlights whose other characteristics are not changed does not constitute a change of headlight type. The same approval number shall accordingly be assigned to such headlights.

** If different types of headlights have an identical glass, the glass may bear the several approval marks of these types of headlights, on condition that the main body of the headlight, even if it cannot be separated from the glass, is also provided with the space referred to in paragraph 3.2. above and bears the approval mark of the type of headlight. If different types of headlights have an identical main body, it may bear the several approval marks for these types of headlights.

*** 1 for the Federal Republic of Germany, 2 for France, 3 for Italy, 4 for the Netherlands, 5 for Sweden, 6 for Belgium, 7 for Hungary, 8 for Czechoslovakia, 9 for Spain, 10 for Yugoslavia, and 11 for the United Kingdom; subsequent numbers will be assigned to other countries in the chronological order in which they ratify or accede to the Agreement concerning the Adoption of Uniform Conditions of Approval and Reciprocal Recognition of Approval for Motor Vehicle Equipment and Parts, and the numbers thus assigned shall be communicated to the Contracting Parties to the Agreement by the Secretary-General of the United Nations.

- 4.3.2.3. on headlights meeting the requirements of this Regulation in respect of the passing beam only, a square containing the letters " HC " placed above the circle;
 - 4.3.2.4. on headlights meeting the requirements of this Regulation in respect of the driving beam only, a square containing the letters " HR " placed above the circle;
 - 4.3.2.5. on headlights meeting the requirements of this Regulation in respect of both the passing beam and the driving beam, a square containing the letters " HCR " placed above the circle;
 - 4.3.2.6. on headlights meeting the requirements of this Regulation in respect of the driving beam, an indication of the maximum luminous intensity expressed by a reference mark, as defined in paragraph 6.3.2.1.2. below placed near the circle surrounding the letter " E ";
 - 4.3.2.7. on lamps, the indication of the rated voltage and the symbol " H₄ ".
- 4.4. The marks and symbols referred to in paragraphs 4.3.1. and 4.3.2. shall be clearly legible and indelible. For headlights, they shall be clearly legible, even when the headlight is fitted on the vehicle.
 - 4.5. Annex 3 to this Regulation provides examples of the arrangement of the approval marks and additional symbols referred to above.

B. TECHNICAL REQUIREMENTS FOR HEADLIGHTS

5. *General specifications*

- 5.1. Each sample shall conform to the specifications set forth in paragraphs 6. to 8. below.
- 5.2. Headlights shall be so designed and made that, in normal use, despite the vibration to which they may then be subjected, their satisfactory operation continues to be ensured and they retain the characteristics prescribed by this Regulation.
- 5.3. The components by which the lamp is fixed to the reflector shall be so made that, even in darkness, the lamp can be fixed in no position but the correct one. *

* A headlight is regarded as satisfying the requirements of this paragraph if the lamp can be easily fitted into the headlight and the feather keys can be correctly fitted into their slots even in darkness. It is considered that an arrangement whereby the lamp is perceptibly tilted when in the wrong position, but not when in the correct position, adequately satisfies the requirements of paragraph 5.3.

- 5.4. Headlights designed to satisfy the requirements both of right-hand and of left-hand traffic may be adapted for traffic on a given side of the road either by an appropriate initial setting when fitted on the vehicle or by selective setting by the user. Such initial or selective setting may consist, for example, of fixing either the optical unit at a given angle on the vehicle or the lamp at a given angle in relation to the optical unit. In all cases, only two different and clearly distinct settings, one for right-hand and one for left-hand traffic, shall be possible, and the design shall preclude inadvertent shifting from one setting to the other or setting in an intermediate position. Where two different setting positions are provided for the lamp, the components for attaching the lamp to the reflector must be so designed and made that, in each of its two settings, the lamp will be held in position with the precision required for headlights designed for traffic on only one side of the road. Conformity with the requirements of this paragraph shall be verified by visual inspection and, where necessary, by a test fitting.

6. *Illumination*

6.1. *General provisions*

- 6.1.1. Headlights shall be so made that with suitable H₄ lamps they give adequate illumination without dazzle when emitting the passing beam, and good illumination when emitting the driving beam.
- 6.1.2. The illumination produced by the headlight shall be determined by means of a vertical screen set up 25 m forward of the headlight as shown in annex 4 to this Regulation.
- 6.1.3. The headlights shall be checked by means of an uncoloured standard (reference) lamp designed for a rated voltage of 12 V. In the case of headlights which may be fitted with selective-yellow filters, * such filters shall be replaced by geometrically identical uncoloured filters with a transmission factor of at least 80 per cent. During the checking of the headlight, the voltage at the terminals of the lamp must be regulated so as to obtain the following characteristics:

	<u>Consumption in watts</u>	<u>Light flux in lumens</u>
passing filament	about 55	750
driving filament	about 60	1250

The headlight shall be considered acceptable if it meets the requirements of this paragraph 6 with at least one standard (reference) lamp, which may be submitted with the headlight.

* These filters shall consist of all the components, including the glass, intended to colour the light (except those forming part of the lamp itself).

- 6.1.4. The dimensions determining the position of the filaments inside the standard lamp are shown in annex 5 to this Regulation.
- 6.1.5. The bulb of the standard lamp must be of such shape and optical quality that it does not cause any reflection or refraction adversely affecting the light distribution. Compliance with this requirement shall be checked by measuring the light distribution obtained when a standard (reference) headlight is fitted with the standard (reference) lamp.
- 6.2. *Provisions concerning passing beams*
- 6.2.1. The passing beam must produce a sufficiently sharp “cut-off” to permit of satisfactory adjustment with its aid. The “cut-off” must be a horizontal straight line on the side opposite to the direction of the traffic for which the headlight is intended; on the other side, it must not extend beyond either the broken line $H H_1 H_4$ formed by a straight line $H H_1$ making a 45° angle with the horizontal and the straight line $H_1 H_4$, 1 per cent above the straight line hh , or the straight line HH_3 , inclined at an angle of 15° above the horizontal (see annex 4.). A cut-off extending beyond both line HH_2 and line H_2H_4 and resulting from a combination of the two above possibilities shall in no circumstances be permitted.
- 6.2.2. The headlight shall be so directed that
- 6.2.2.1. in the case of headlights designed to meet the requirements of right-hand traffic, the “cut-off” on the left half of the screen * is horizontal and, in the case of headlights designed to meet the requirements of left-hand traffic, the “cut-off” on the right half of the screen is horizontal;
- 6.2.2.2. this horizontal part of the “cut-off” is situated on the screen 25 cm below the level of the horizontal plane passing through the focus of the headlight (see annex 4.);
- 6.2.2.3. the “elbow” of the “cut-off” is on line vv **.
- 6.2.3. When so directed, the headlight need, if its approval is sought solely for provision of a passing beam ***, comply only with the requirements set out in paragraphs 6.2.5. to 6.2.7. below; if it is intended to provide both a passing beam and a driving beam, it shall comply with the requirements set out in paragraphs 6.2.5. to 6.2.7. and 6.3.

* The test screen must be sufficiently wide to allow examination of the “cut-off” over a range of at least 5° on either side of the line vv .

** If the beam does not have a cut-off with a clear “elbow”, the lateral adjustment shall be effected in the manner which best satisfies the requirements for illumination at points 75 R and 50 R for right-hand traffic and for points 75 L and 50 L for left-hand traffic.

*** Such a special “passing beam” headlight may incorporate a driving beam not subject to requirements.

- 6.2.4. Where a headlight so directed does not meet the requirements set out in paragraphs 6.2.5. to 6.2.7. and 6.3., its alignment may be changed, provided that the axis of the beam is not displaced laterally by more than 1° (= 44 cm) to the right or left. * To facilitate alignment by means of the "cut-off", the headlight may be partially occulted in order to sharpen the "cut-off".
- 6.2.5. The illumination produced on the screen by the passing beam shall meet the following requirements:

<i>Point on measuring screen</i>		<i>Required illumination in lux</i>
<i>Headlights for right-hand traffic</i>	<i>Headlights for left-hand traffic</i>	
Point B 50 L	Point B 50 R	≤ 0.4
Point 75 R	Point 75 L	≥ 12
Point 75 L	Point 75 R	≥ 12
Point 50 L	Point 50 R	≥ 15
Point 50 R	Point 50 L	≥ 12
Point 50 V	Point 50 V	≥ 6
Point 25 L	Point 25 R	≥ 2
Point 25 R	Point 25 L	≥ 2
Any point in zone III		≤ 0.7
Any point in zone IV		≥ 3
Any point in zone I $\leq 2 \times (E_{50 R} \text{ or } E_{50 L})$ †		

† $E_{50 R}$ and $E_{50 L}$ are the illuminations actually measured.

- 6.2.6. There shall be no lateral variations detrimental to good visibility in any of the zones I, II, III and IV.
- 6.2.7. Headlights designed to meet the requirements of both right-hand and left-hand traffic must, in each of the two setting positions of the optical unit or of the lamp, meet the requirements set forth above for the corresponding direction of traffic.

6.3. Provisions concerning driving beams

- 6.3.1. In the case of a headlight designed to provide a driving beam and a passing beam, measurements of the illumination produced on the screen by the driving beam shall be taken with the same headlight alignment as for measurements under paragraphs 6.2.5 to 6.2.7 above; in the case of a headlight providing a driving beam only, it shall be so adjusted that the area of maximum illumination is centred on the point of intersection of lines hh and vv; such a headlight need meet only the requirements referred to in paragraph 6.3.

* The limit of re-alignment of 1° towards the right or left is not incompatible with upward or downward vertical re-alignment. The latter is limited only by the requirements of paragraph 6.3. However, the horizontal part of the "cut-off" should not extend beyond the line hh (the provisions of paragraph 6.3. are not applicable to headlights intended to meet the requirements of this Regulation only for provision of a passing beam).

- 6.3.2. The illumination produced on the screen by the driving beam shall meet the following requirements:
- 6.3.2.1. The point of intersection (H) of lines hh and vv shall be situated within the isolux 80 per cent of maximum illumination. This maximum value (E_M) shall not be less than 48 lux. The maximum value shall not exceed 240 lux or, in the case of a combined passing and driving headlight, be more than 16 times the illumination measured for the passing beam at point 75 R (or 75 L).
- 6.3.2.1.1. The maximum intensity (I_M) of the driving beam expressed in thousands of candelas shall be calculated by the formula
- $$I_M = 0.625 E_M$$
- 6.3.2.1.2. The reference mark (I'_M) of this maximum intensity, referred to in paragraph 4.3.2.6. above, shall be obtained by the ratio
- $$I'_M = \frac{I_M}{3} = 0.208 E_M \quad (12)$$
- This value shall be rounded off to the nearest 10, 20, 25, 30, 40 or 50.*
- 6.3.2.2. Starting from point H, horizontally to the right and left, the illumination shall be not less than 24 lux up to a distance of 1.125 m and not less than 6 lux up to a distance of 2.25 m.
- 6.4. The screen illumination values mentioned in paragraphs 6.2.5 to 6.2.7. and 6.3. above shall be measured by means of a photo-receptor, the effective area of which shall be contained within a square of 65 mm side.

7. Provisions concerning coloured glasses and filters

- 7.1. Approval may be obtained for headlights emitting either colourless or selective-yellow lights with an uncoloured lamp. Expressed in ICI trichromatic co-ordinates, the corresponding colorimetric characteristics for yellow glasses or filters are as follows:

Selective-yellow filter (screen or glass)

Trichromatic co-ordinates:

Limit towards red	$y \geq 0.138 + 0.58 x$
Limit towards green	$y \leq 1.29 x - 0.1$
Limit towards white	$y \geq -x + 0.966$
Limit towards spectral value y	$y \leq -x + 0.992$

* The total intensity of the driving beams of all the headlights of one vehicle used simultaneously must not exceed a maximum value of 300,000 candelas. It is therefore conventionally accepted that the sum of the numbers forming the reference mark should not, in any one vehicle and for all the headlights which can be used simultaneously, exceed 100. In order to enable the authorities to test a vehicle equipped with headlights for which marking is not at present imposed (E headlight according to Regulations Nos. 1 and 5 and H headlights according to Regulation No. 8), it is recommended that the reference mark 10 should be conventionally assigned to all E headlights with driving beams and reference mark 20 to all H headlights with driving beams.

which can also be expressed as follows:

dominant wave-length: 575-585 nm

purity factor: 0.90-0.98

The transmission factor must be ≥ 0.78 .

The transmission factor shall be determined by using a light source with a colour temperature of 2854°K.*

7.2. The filter must be part of the headlight, and must be attached to it in such a way that the user cannot remove it either inadvertently or, with ordinary tools, intentionally.

8. *Gauging of discomfort*

The discomfort caused by the passing beam of headlights shall be gauged.**

9. *Standard (reference) headlight ****

A headlight shall be deemed to be a standard (reference) headlight if it

9.1. satisfies the above-mentioned requirements for approval;

9.2. has an effective diameter of not less than 160 mm;

9.3. provides, with a standard (reference) lamp, at the various points and in the various zones referred to in paragraph 6.2.5., illumination equal to:

9.3.1. not more than 90 per cent of the maximum limits, and

9.3.2. not less than 120 per cent of the minimum limits, prescribed in the table in paragraph 6.2.5.

10. *Observation concerning colour*

Since any approval under this Regulation is granted, pursuant to paragraph 7.1. above, for a type of headlight emitting either colourless light or selective-yellow light, article 3 of the Agreement to which the Regulation is annexed shall not prevent the Contracting Parties from prohibiting headlights emitting a beam of uncoloured or selective-yellow light on vehicles registered by them.

C. TECHNICAL REQUIREMENTS FOR H₄ LAMPS

11. *General specifications*

11.1. Each sample shall conform to the electrical and photometric specifications set forth in paragraph 13, below.

* Corresponding to illuminant A of the International Commission on Illumination (ICI).

** This requirement will be the subject of a recommendation to administrations.

*** Different values may be accepted provisionally. In the absence of definitive specifications, the use of an approved headlight is recommended.

- 11.2. All measurements shall be carried out at the " test voltage ".
- 11.3. Lamps must be so made as to be, and to remain, in good working order when in normal use. They shall, moreover, exhibit no fault in design or manufacture.

12. *Manufacture*

- 12.1. Lamp bulbs shall have no scores or spots which might impair their efficiency.
- 12.2. Lamps shall have a cap conforming to the standard type shown in annex 6 to this Regulation.
- 12.3. The position, shape and dimensions of the filament and of the shield inside the lamp shall conform to the specifications shown in annex 5 to this Regulation.
- 12.4. The cap shall be strong and firmly secured to the bulb.
- 12.5. To ascertain whether lamps conform to the provisions of paragraphs 12.1. to 12.4. above, a visual inspection, a dimension check and, where necessary, a test fitting, shall be carried out. The dimensions referred to in paragraph 12.3. above shall be checked on lamps supplied with current at their test voltage, and, where necessary, by means of a projection system.

13. *Light flux and wattage*

- 13.1. The luminous flux and wattage shall remain within the limits shown in annex 5 to this Regulation.
- 13.2. The test shall be made with the lamp in its normal position of use and supplied with current at its test voltage after having been lit for one hour under the same conditions.

14. *Colour*

The bulb of the lamps shall be colourless; however, lamps may be made with a double bulb, the outer bulb forming a yellow filter and being an integral part of the lamp. In such case, two samples of this outer bulb, separated from the lamp, shall be tested to ensure that the colorimetric characteristics, expressed in ICI Trichromatic co-ordinates, conform to the values shown in paragraph 7.1.

15. *Optical quality check*

The sample which most nearly meets the provisions laid down for the standard (reference) lamp may be tested in a standard (reference) headlight to ensure that the assembly consisting of this headlight and the lamp

being tested meets the approval requirements for headlights. Lamps having a double bulb, the outer bulb forming a yellow filter, shall also be checked to ensure that the minimum illumination required is 85 per cent of that shown in paragraph 6.2.5., the maximum illumination remaining the same.

D. COMMON PROVISIONS

16. *Conformity of production*

Every headlight and every lamp bearing an approval mark as provided for in this Regulation must conform to the approved type and meet the photometric requirements set forth above. As regards headlights, compliance with this provision shall be verified in accordance with annex 2 to this Regulation.

17. *Penalties for non-conformity of production*

17.1. The approval granted in respect of a headlight or a lamp may be withdrawn if the requirements set forth above are not met.

17.2. If a Contracting Party to the Agreement withdraw an approval it has previously granted, it shall forthwith notify the other Contracting Parties applying this Regulation thereof by means of a copy of the approval form bearing at the end in large letters the signed and dated annotation "APPROVAL WITHDRAWN".

18. *Names and addresses of technical services responsible for approval tests, and of administrative departments*

The Parties to the Agreement applying this Regulation shall communicate to the Secretariat of the United Nations the names and addresses of the technical services conducting approval tests and of the administrative departments which grant approval and to which forms certifying approval or refusal or withdrawal of approval, issued, in other countries, are to be sent.

ANNEX 1

Model A

[Maximum format: A 4 (210 × 297 mm)]

NAME OF
ADMINISTRATION

COMMUNICATION CONCERNING THE APPROVAL
(OR REFUSAL OR WITHDRAWAL OF APPROVAL)
OF A TYPE OF H₄ HEADLIGHT PURSUANT
TO REGULATION No. 20

Approval No.

1. Headlight submitted for approval as type
HC, HC, HC, HC, HR, HCR, HCR, HCR *
2. Headlight emitting, with a colourless lamp: a colourless beam,
a selective yellow beam *
3. Trade name or mark
4. Manufacturer's name
5. Name of his representative (if applicable)
6. Address
7. Submitted for approval on
8. Technical service conducting approval tests
9. Date of report issued by that service
10. Number of report issued by that service
11. Approval granted/refused *
12. Maximum illumination (in lux) of the driving beam at 25 m from
the headlight (average for two headlights)
13. Place
14. Date
15. Signature
16. The attached drawing No. shows the headlight.

* Strike out what does not apply.

Model B

[Maximum format: A 4 (210 × 297 mm)]



NAME OF
ADMINISTRATION

COMMUNICATION CONCERNING THE APPROVAL
(OR REFUSAL OR WITHDRAWAL OF APPROVAL)
OF A TYPE OF H₄ LAMP PURSUANT
TO REGULATION No. 20

Approval No.

- 1. Lamps
 - rated voltage
 - rated wattage
 - fitted with a yellow filter: yes/no *
- 2. Trade name or mark
- 3. Manufacturer's name
- 4. Name of his representative (if applicable)
- 5. Address
- 6. Submitted for approval on
- 7. Technical service conducting approval tests
- 8. Date of report issued by that service
- 9. Number of report issued by that service
- 10. Approval granted/refused *
- 11. Place
- 12. Date
- 13. Signature
- 14. The attached drawing No. shows the entire lamp.

* Strike out what does not apply.

ANNEX 2

VERIFICATION OF CONFORMITY OF PRODUCTION OF HEADLIGHTS
EQUIPPED WITH H₄ LAMPS

1. Headlights bearing an approval mark shall conform to the approved type.
2. The requirement of conformity shall be deemed satisfied from a mechanical geometrical standpoint if the discrepancies do not exceed inevitable manufacturing errors.
3. As regards photometric performance, the conformity of headlights of the series will not be contested * if, during photometric tests of any headlight, selected at random and equipped with a standard (reference) lamp,
 - 3.1. none of the values measured deviates unfavourably by more than 20 per cent from the prescribed value (for values B50R or L and zone III, the maximum unfavourable deviation may be 0.2 lux (B50R or L), or 0.3 lux (zone III));
 - 3.2. or if
 - 3.2.1. for the passing beam, the prescribed values are met at HV (with a tolerance of 0.2 lux) and at least one point of the area delimited on the measuring screen (at 25 m) by a circle 15 cm in radius around points B50R or L (with a tolerance of 0.1 lux), 75R or L, 50 R or L, 25R or L, and in the entire area of zone IV which is not more than 22.5 cm above line 25R and 25L,
 - 3.2.2. and if, for the driving beam, HV being situated within the isolux 0.75 E_{max}, a tolerance of 20 percent is observed for the photometric values.**
 4. If the results of the tests described in paragraph 3 above do not satisfy the requirements, the tests for the headlight in question shall be repeated with another standard (reference) lamp.

* It is recommended that the authorities of the country of manufacture should refer to the results of any statistical checks made by the manufacturer rather than undertake the checks mentioned in paragraph 3.

** The determination of the maximum value (16) of the ratio between the maximum illumination of the driving beam and the illumination at point 75 R (or 75 L) provided for in paragraph 6.3.2.1. of this Regulation is solely for the purpose of seeing whether the type of headlight has the desired characteristics; no such check need be made during verification of conformity of production.

ANNEX 3

ARRANGEMENT OF THE APPROVAL MARK

A. Lamps

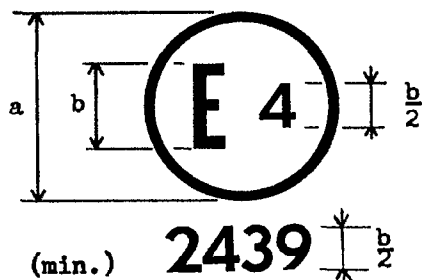

Dimensions for lamps	a	b
I	5	2.3
II	8	3.7

(millimetres)

The lamp bearing the above approval mark has been approved in the Netherlands (E4) under No. 2439.

B. Headlights

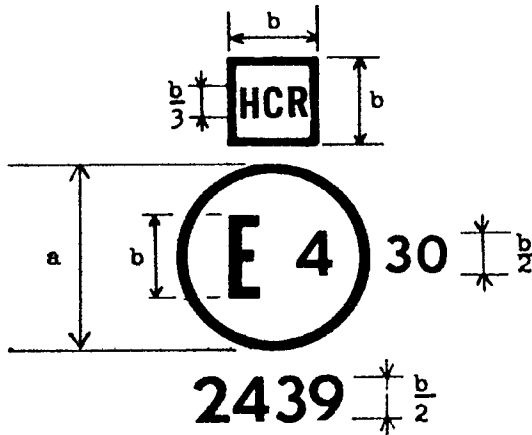

Dimensions for headlights	a	b
III	12	5.6
IV	18	8.5

(millimetres)

Fig. 1

The headlight bearing the above approval mark is a headlight meeting the requirements of this Regulation in respect of both the passing beam and the driving beam and is designed for right-hand traffic only.

The figure 30 indicates that the maximum intensity of the driving beam is between 82,500 and 105,000 candelas.

B. Headlights (continued)

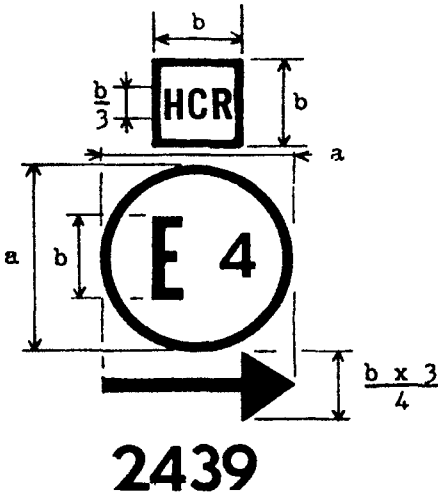

Fig. 2

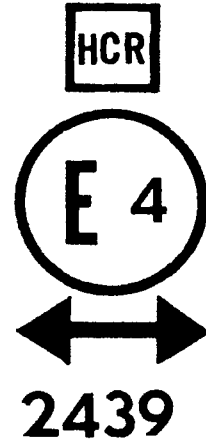
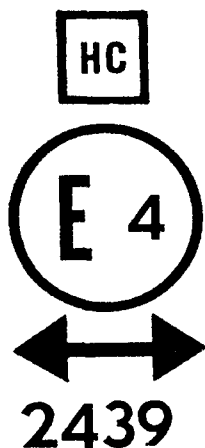
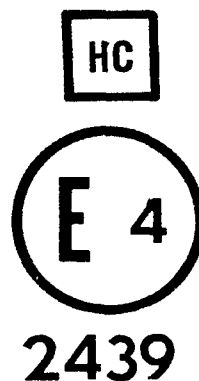

Fig. 3

The headlight bearing the above approval mark meets the requirements of this Regulation in respect of both the passing beam and the driving beam and is designed:

— for left-hand traffic only.

— for both traffic systems, by means of an appropriate adjustment of the setting of the optical unit or the lamp on the vehicle.

B. *Headlights* (continued)*Fig. 4**Fig. 5*

The headlight bearing the above approval mark is a headlight meeting the requirements of this Regulation in respect of the passing beam only and is designed:

— for both traffic systems.

— for right-hand traffic only.

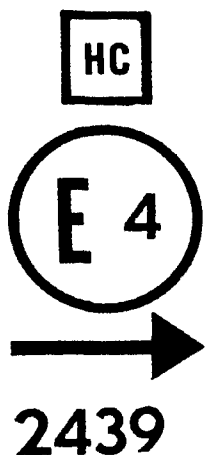
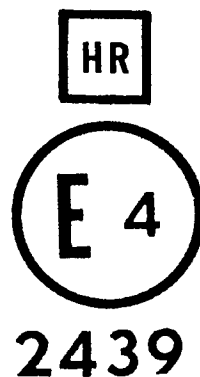
B. *Headlights* (continued)*Fig. 6**Fig. 7*

The headlight bearing the above approval mark is a headlight meeting the requirements of this Regulation

— in respect of the passing beam only and is designed for left-hand traffic only.

— in respect of the driving beam only.

ANNEX 4

MEASURING SCREEN

A. Headlight for right-hand traffic
(Dimensions in mm)

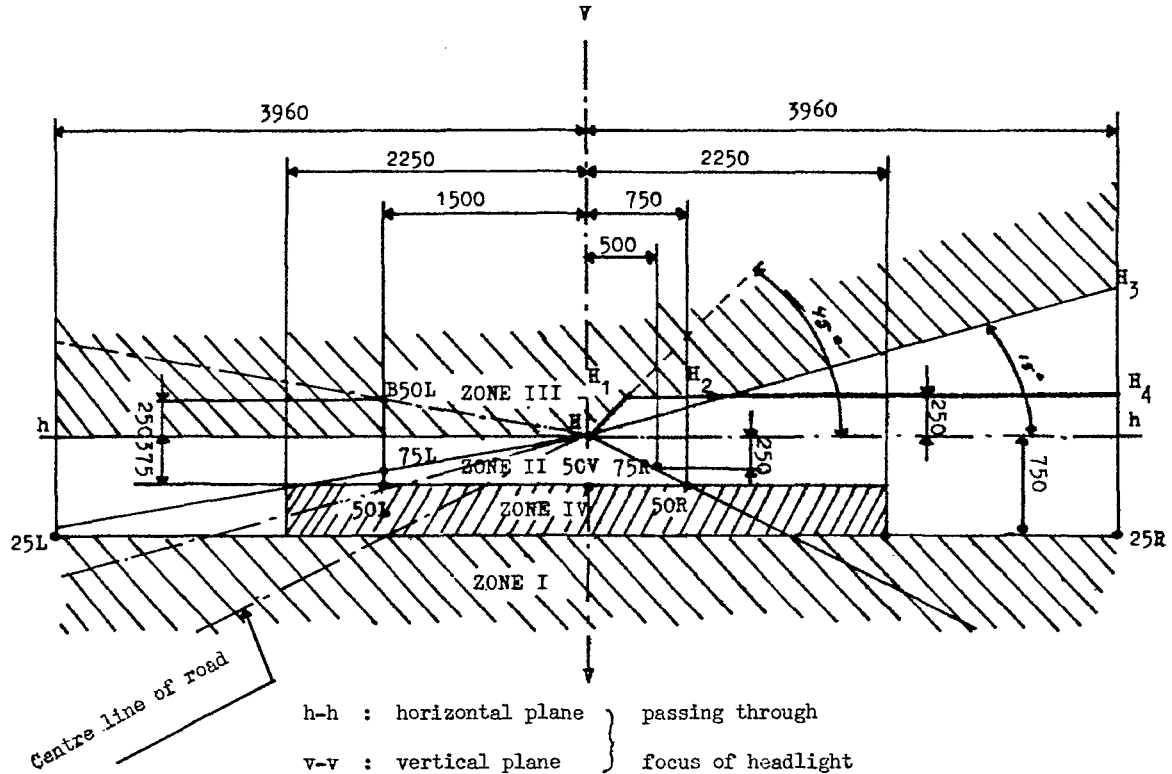

STANDARD EUROPEAN BEAM

STANDARD EUROPEAN BEAM

B. Headlight for left-hand traffic
(Dimensions in mm)

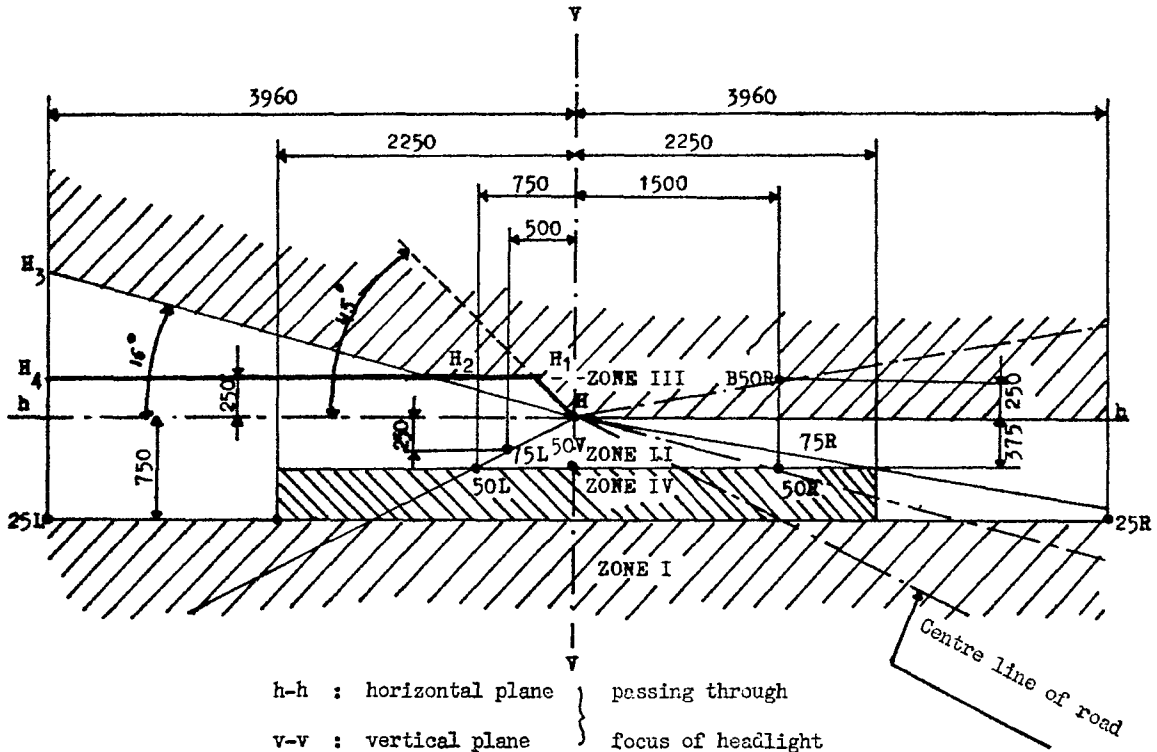

ANNEX 5

ASYMMETRIC H₄ HALOGEN MOTOR VEHICLE LAMP WITH P43t-38 CAP *

Fig. 1

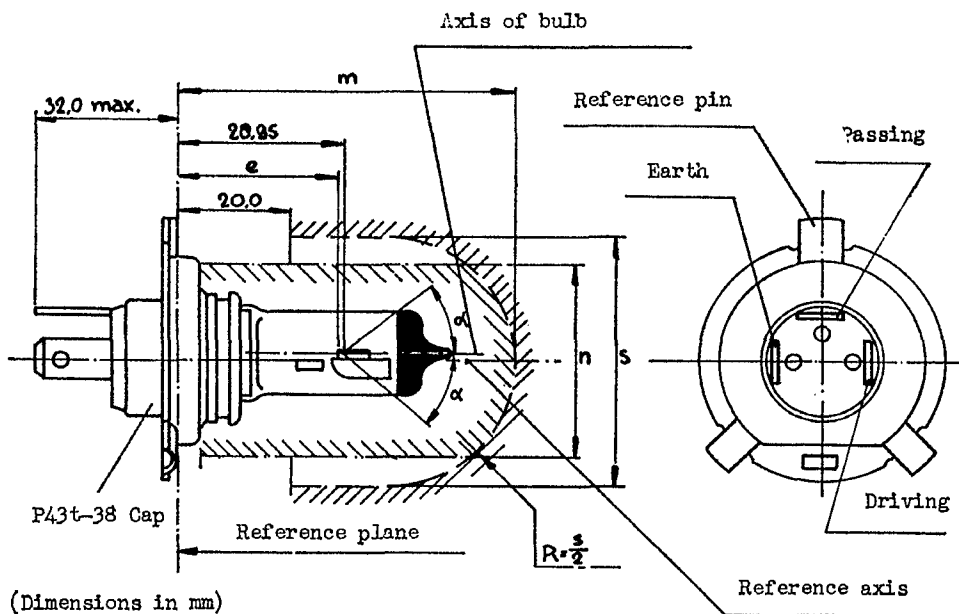

Reference	Dimension	Tolerance
e 2/	28.5	+ 0.45 - 0.25
m 1/	max. 60.0	-
n 1/	max. 34.5	-
s 2/	45.0	-
α 2/	max. 40°	-

* The drawings are not mandatory but are intended only to indicate the dimensions to be verified.

Characteristics *

		Driving beam filament	Passing beam filament	
Rated values	Volts	12 *		
		60	55	
Measuring flux		1250	750	
Test voltage		13.2		
Values at test voltage	Watts ⁴		max. 75	max. 68
	Luminous flux	Specified value	1650	1000
		Tolerance ⁴ ± %	15	15

* Values for lamps with other rated voltages are under consideration.

EXPLANATORY NOTES

¹ When a yellow outer bulb is used, "m" and "n" denote the maximum dimensions of this bulb; when there is no outer bulb, "m" denotes the maximum length of the lamp.

² It should be possible to insert the lamp in a cylinder of diameter "s" concentric to the reference axis and limited at one end by a plane parallel to the reference plane at a distance of 20 mm from it and at the other end by a semisphere of radius $\frac{s}{2}$.

³ The obscuration should extend at least as far as the cylindrical portion of the bulb. It should also overlap the internal shield when viewed in a direction perpendicular to the reference axis. The effect which it is desired to produce by the obscuration may also be achieved by other means.

⁴ Applies to 90 per cent of production.

Fig. 2. Position of shield *

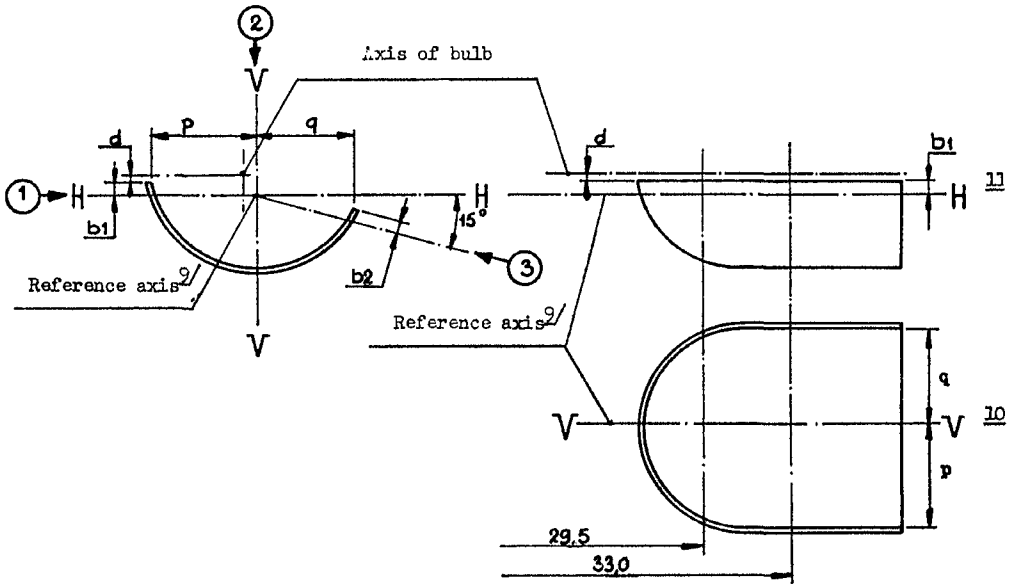

* The drawing is not mandatory with respect to the design of the shield.

Fig. 3. Position of filaments *

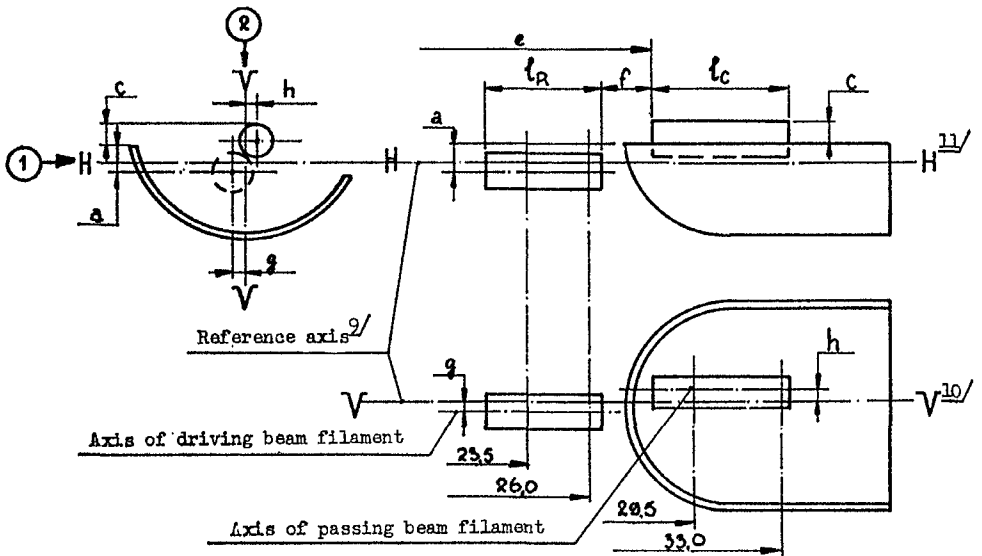

* The drawing is not mandatory with respect to the design of the shield.

Table of dimensions mentioned on Fig. 2 and 3 (in mm)

Dimensions are measured in three reference directions:

- ① for dimensions a, b₁, c, d, e, f, l_R and l_C
- ② for dimensions g, h, p and q
- ③ for dimensions b₂

Dimensions p and q are measured in a plane parallel to the reference plane at a distance of 33 mm from it.

Dimensions b₁, b₂, c and h are measured in planes parallel to the reference plane at distances of 29.5 mm and 33 mm.

Dimensions a and g are measured in planes parallel to the reference plane at distances of 26.0 mm and 23.5 mm from it.

Reference †	Dimension	Tolerance ¹²	
		Production sample	Standard (reference) lamp
a/26	0.8	± 0.35	± 0.2
a/23.5	0.8	± 0.60	± 0.2
b ₁ /29.5	0	± 0.35	± 0.2
b ₁ /33	b ₁ /29.5 mv ††	± 0.35	± 0.15
b ₂ /29.5	0	± 0.35	± 0.2
b ₂ /33	b ₂ /29.5 mv ††	± 0.35	± 0.15
c/29.5	0.6	± 0.35	± 0.2
c/33	c/29.5 mv ††	± 0.35	± 0.15
d	min 0.1	—	—
e ⁷	28.5	+ 0.45	+ 0.2
		— 0.25	— 0.0
f ^{5, 6, 8}	1.7	+ 0.50	+ 0.3
		— 0.30	— 0.1
g/26	0	± 0.5	± 0.3
g/23.5	0	± 0.7	± 0.3
h/29.5	0	± 0.5	± 0.3
h/33	h/29.5 mv ††	± 0.35	± 0.2
l _R ^{5, 8}	4.5	± 0.8	± 0.4
l _C ^{5, 6}	5.5	± 0.8	± 0.35
p/33	Depends on the shape of the shield	—	—
q/33	$\frac{p+q}{2}$	± 0.6	± 0.3

† Dimension to be measured in mm at the distance from the reference plane indicated after the stroke.

†† “. /29.5 mv ” means the value measured at a distance of 29.5 mm from the reference plane.

EXPLANATORY NOTES

⁵ The end turns of the filaments are defined as the first and last luminous turns that are substantially at the correct helix angle. The filaments should be operated at test voltage during measurement.

⁶ For the passing beam filament, the points to be measured are the intersections, seen in direction ①, of the edge of the shield with the outside of the end turns defined under ⁵.

⁷ "e" denotes the distances from the reference plane to the beginning of the passing beam filament as defined above.

⁸ For the driving beam filament, the points to be measured are the intersections, viewed in direction ①, of a plane, parallel to plane HH and situated at a distance of 0.8 mm below it, with the end turns defined under ⁵.

⁹ The reference axis is the line perpendicular to the reference plane and passing through the centre of the circle diameter "M" (see annex 6).

¹⁰ Plane VV is the plane perpendicular to the reference plane and passing through the reference axis and the intersection of the circle of diameter "M" with the axis of the reference pin.

¹¹ Plane HH is the plane perpendicular to both the reference plane and plane VV, passing through the reference axis.

¹² The tolerances allowed for production samples correspond to the test requirements for the approval of a given type of lamp. Those allowed for the entire production must meet the requirements for conformity of production.

ANNEX 6

PREFOCUS CAP FOR MOTOR VEHICLE LAMP ASSEMBLY OF RING
AND P43t-38 CAP ON FINISHED LAMP *

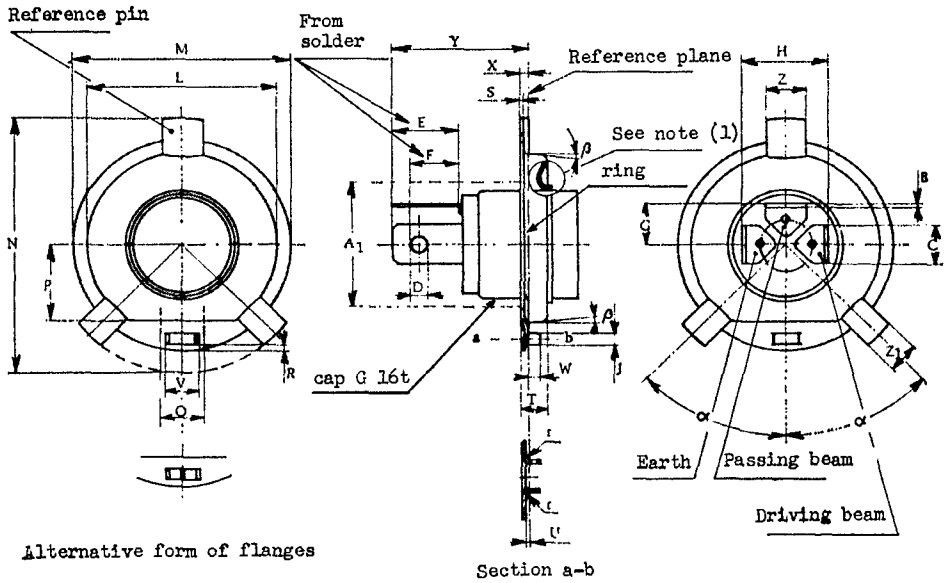

* The drawing is not mandatory but is intended only to indicate the dimensions to be verified.

Table of dimensions
(in mm)

<i>Dimension</i>	<i>Min.</i>	<i>Max.</i>	<i>Dimensions</i>	<i>Min.</i>	<i>Max.</i>
A ₁ ⁸	25.0	—	R	1.3	1.7
B	0.7	0.8	S	0.5	—
C ⁹	7.7	8.1	T	5.0	6.0
D	3.0	3.3	U	— ¹⁰	
E ⁹	11.8	13.6	V ^{2, 5}	6.3	6.5
F	8.8	10.3	W	1.8	2.2
G ^{6, 9}	8.5	9.0	X	1.1	1.3
H ^{6, 9}	17.0	17.9	Y	—	32.0
J	1.9	2.1	Z ⁶	7.9	8.0
L ^{2, 4}	37.8	38.0	Z ₁	5.8	6.2
M ³	42.8	43.0	r	— ¹⁰	
N	51.6	52.0	α	44°	46°
P ^{2, 7}	15.3	15.5	β	—	5°
Q ^{2, 7}	8.5	—			

EXPLANATORY NOTES

¹ This part may be flat or recessed. This part of the cap must not, by reflecting the light emitted by the passing beam, cause abnormal dazzle when the lamp is in normal operating position on the vehicle.

² These dimensions are measured in the reference plane. The flanged parts shall not project outwards.

³ Dimension M is the diameter on which the lamp is centred when the geometrical characteristics of the lamp are checked.

⁴ The maximum permissible eccentricity of cylinder L with respect to the circle of diameter M is 0.05 mm.

⁵ The maximum permissible displacement of the centre of the flanges from the line passing through the centre of the reference pin and the centre of the circle of diameter M is 0.05 mm.

⁶ The relative positions of the contact plates and the reference pin must not deviate from the positions shown in the drawing by more than 20°.

⁷ Dimension Q denotes the minimum distance over which dimension P must conform.

⁸ The systems for fixing the ring in the headlight must not encroach on this cylindrical zone.

⁹ Dimensions C min. and E and the relative position of the contact plates shall be checked by means of the gauge shown on sheet 7009-95.-1 of ICI publication 61 — 3rd edition — 1969.

¹⁰ The radius r must not exceed dimension U.