

ANNEX A — ANNEXE A

No. 4789. AGREEMENT CONCERNING THE ADOPTION OF UNIFORM CONDITIONS OF APPROVAL AND RECIPROCAL RECOGNITION OF APPROVAL FOR MOTOR VEHICLE EQUIPMENT AND PARTS. DONE AT GENEVA ON 20 MARCH 1958¹

ENTRY INTO FORCE of Regulation No. 66 (*Uniform provisions concerning the approval of large passenger vehicles with regard to the strength of their superstructure*) as an annex to the above-mentioned Agreement of 20 March 1958

The said Regulation came into force on 1 December 1986 in respect of Hungary and the United Kingdom of Great Britain and Northern Ireland, in accordance with article 1(5) of the Agreement.

REGULATION NO. 66

Uniform provisions concerning the approval of large passenger vehicles with regard to the strength of their superstructure

1. SCOPE

This Regulation applies to single-decked vehicles constructed for the carriage of more than 16 passengers, whether seated or standing, in addition to the driver and crew.*

2. DEFINITIONS

For the purposes of this Regulation:

- 2.1. "Approval of a vehicle" means the approval of a vehicle type with regard to the construction features specified in this Regulation;
- 2.2. "Vehicle type" means a category of vehicles which do not differ essentially in respect of the constructional features specified in this Regulation;
- 2.3. "Passenger compartment" means the space intended for passengers' use excluding any space occupied by fixed appliances such as bars, kitchenettes or toilets;

* Nothing in this Regulation shall prevent the Contracting Parties from restricting its scope to particular categories of vehicle.

¹ United Nations, *Treaty Series*, vol. 335, p. 211; for subsequent actions, see references in Cumulative Indexes Nos. 4 to 14, as well as annex A in volumes 915, 917, 926, 932, 940, 943, 945, 950, 951, 955, 958, 960, 961, 963, 966, 973, 974, 978, 981, 982, 985, 986, 993, 995, 997, 1003, 1006, 1010, 1015, 1019, 1020, 1021, 1024, 1026, 1031, 1035, 1037, 1038, 1039, 1040, 1046, 1048, 1050, 1051, 1055, 1059, 1060, 1065, 1066, 1073, 1078, 1079, 1088, 1092, 1095, 1097, 1098, 1106, 1110, 1111, 1112, 1122, 1126, 1130, 1135, 1136, 1138, 1139, 1143, 1144, 1145, 1146, 1147, 1150, 1153, 1156, 1157, 1162, 1177, 1181, 1196, 1197, 1198, 1199, 1205, 1211, 1213, 1214, 1216, 1218, 1222, 1223, 1224, 1225, 1235, 1237, 1240, 1242, 1247, 1248, 1249, 1252, 1253, 1254, 1255, 1256, 1259, 1261, 1271, 1273, 1275, 1276, 1277, 1279, 1284, 1286, 1287, 1291, 1293, 1294, 1295, 1299, 1300, 1301, 1302, 1308, 1310, 1312, 1314, 1316, 1317, 1321, 1323, 1324, 1327, 1328, 1330, 1331, 1333, 1335, 1336, 1342, 1347, 1348, 1349, 1350, 1352, 1355, 1358, 1361, 1363, 1364, 1367, 1374, 1379, 1389, 1390, 1392, 1394, 1398, 1401, 1402, 1404, 1405, 1406, 1408, 1409, 1410, 1412, 1413, 1417, 1419, 1421, 1422, 1423, 1425, 1428, 1429, 1434, 1436 and 1438.

- 2.4. "Driver's compartment" means the space intended for the driver's exclusive use and containing the driver's seat, the steering wheel, controls, instruments and other devices necessary for driving the vehicle;
- 2.5. "Unladen kerb mass" means the mass of the vehicle in running order, unoccupied and unladen but complete with fuel, coolant, lubricant, tools and spare wheel, if any;
- 2.6. "Residual space" means the space to be preserved in the passenger compartment during and after the structure has been subjected to one of the tests prescribed in paragraph 6 of this Regulation;
- 2.7. "Superstructure" means the parts of a vehicle structure which contribute to the strength of the vehicle in the event of a roll-over accident;
- 2.8. "Body section" means a section containing at least two identical vertical pillars on each side representative of a part or parts of the structure of the vehicle;
- 2.9. "Total energy" means the energy assumed to be absorbed by the complete structure of the vehicle. This may be determined as shown in appendix 1 of annex 5 to this Regulation.

3. APPLICATION FOR APPROVAL

- 3.1. The application for approval of a vehicle type with regard to the strength of its superstructure shall be submitted by the vehicle manufacturer or by his duly accredited representative.
- 3.2. It shall be accompanied by three copies of each of the undermentioned documents and by the following particulars:
 - 3.2.1. a detailed description of the superstructure of the vehicle type including its dimensions, configuration and constituent materials and its attachment to any chassis frame;
 - 3.2.2. drawings of the vehicle and those parts of its interior arrangement which have an influence on the strength of the superstructure or on the residual space;
 - 3.2.3. particulars of:
 - 3.2.3.1. the unladen kerb mass (kg)
(In the case of an articulated bus this information shall be given separately for the two rigid portions);
 - 3.2.3.2. the unladen kerb mass for each axle (kg);
 - 3.2.3.3. the position of the centre of gravity of the unladen vehicle in the longitudinal, transverse and vertical directions;
 - 3.2.3.4. the maximum distance between the centre lines of the outboard passenger seats.
- 3.3. Either a complete vehicle or one or more sections of the superstructure representative of the type to be approved shall be submitted to the technical service responsible for conducting the approval tests unless the approval is to be conducted by means of calculation, in which case the calculation shall be submitted to the technical service.
- 3.4. The competent authority shall verify the existence of satisfactory arrangements for ensuring effective control of the conformity of production before type approval is granted.

4. APPROVAL

- 4.1. If the vehicle submitted for approval to this Regulation meets the requirements of paragraph 5 below, approval of that vehicle type shall be granted.

- 4.2. An approval number shall be assigned to each vehicle type approved. Its first two digits (at present 00 for the Regulation in its original form) shall indicate the series of amendments incorporating the most recent major technical amendments made to the Regulation at the time of issue of the approval. The same Contracting Party shall not assign the same number to another vehicle type as defined in paragraph 2.2. above.
- 4.3. Notice of approval or of refusal or extension of approval of a vehicle type pursuant to this Regulation shall be communicated to the Parties to the Agreement which apply this Regulation, by means of a form conforming to the model in annex 1 to this Regulation and of drawings and diagrams supplied by the applicant for approval, in a format not exceeding A4 (210 × 297 mm) or folded to that format and on an appropriate scale.
- 4.4. There shall be affixed, conspicuously and in a readily accessible place specified on the approval form, to every vehicle conforming to a vehicle type approved under this Regulation an international approval mark consisting of:
 - 4.4.1. a circle surrounding the letter "E" followed by the distinguishing number of the country which has granted approval;¹
 - 4.4.2. the number of this Regulation, followed by the letter "R", a dash and the approval number to the right of the circle prescribed in paragraph 4.4.1.
- 4.5. The approval mark shall be clearly legible and be indelible.
- 4.6. The approval mark shall be placed close to or on the vehicle data plate affixed by the manufacturer.
- 4.7. Annex 2 to this Regulation gives an example of the approval mark.

5. GENERAL SPECIFICATIONS AND REQUIREMENTS

- 5.1. The superstructure of the vehicle shall be of sufficient strength to ensure that during and after it has been subjected to one of the methods of test or calculation prescribed in paragraph 6:
 - 5.1.1. No displaced part of the vehicle intrudes into the residual space, as specified in paragraph 7, and
 - 5.1.2. No part of the residual space projects outside the deformed structure.
- 5.2. The requirements of paragraph 5.1. above shall apply to the vehicle including all its structural parts, members and panels and all projecting rigid parts such as luggage racks, ventilation equipment, etc. However, bulkheads, partitions, rings or other members reinforcing the superstructure of the vehicle and fixed appliances such as bars, kitchenettes or toilets shall be ignored for the purposes of paragraph 5.1.
- 5.3. In the case of an articulated vehicle each part of the vehicle shall comply with the requirements specified in paragraph 5.1. above.

¹ 1 for the Federal Republic of Germany, 2 for France, 3 for Italy, 4 for the Netherlands, 5 for Sweden, 6 for Belgium, 7 for Hungary, 8 for Czechoslovakia, 9 for Spain, 10 for Yugoslavia, 11 for the United Kingdom, 12 for Austria, 13 for Luxembourg, 14 for Switzerland, 15 for the German Democratic Republic, 16 for Norway, 17 for Finland, 18 for Denmark, 19 for Romania, 20 for Poland, 21 for Portugal and 22 for the Union of Soviet Socialist Republics. Subsequent numbers shall be assigned to other countries in the chronological order in which they ratify or accede to the Agreement concerning the Adoption of Uniform Conditions of Approval and Reciprocal Recognition of Approval for Motor Vehicle Equipment and Parts, and the numbers thus assigned shall be communicated by the Secretary-General of the United Nations to the Contracting Parties to the Agreement.

6. TEST METHODS

- 6.1. Each type of vehicle shall be verified according to one of the following methods at the discretion of the manufacturer or according to an alternative method approved by the competent authority:
 - 6.1.1. A roll-over test on a complete vehicle in accordance with the procedure set out in annex 3 to this Regulation;
 - 6.1.2. A roll-over test on a body section or sections representative of a complete vehicle in accordance with annex 4 to this Regulation;
 - 6.1.3. A pendulum test on a body section or sections in accordance with annex 5 to this Regulation; or
 - 6.1.4. A verification of strength of superstructure by calculation in accordance with annex 6 to this Regulation.
- 6.2. If the methods prescribed in paragraphs 6.1.2., 6.1.3. or 6.1.4. cannot take account of a significant variation between one section of the vehicle and another, for example an air-conditioning installation on the roof, additional test methods or calculations shall be submitted to the technical service. In the absence of such additional information the vehicle may be required to undergo the method of test prescribed in paragraph 6.1.1.

7. RESIDUAL SPACE

- 7.1. For the purpose of paragraph 5.1. of this Regulation, the residual space means the volume within the passenger compartment which is swept when the transverse vertical plane defined in figure 1 (a) of this Regulation is moved in a straight line or lines so that the point "R" in figure 1 (a) passes from the "R" point of the rearmost outer seat, through the "R" point of every intermediate outer seat to the "R" point of the foremost outer passenger seat.
- 7.2. The position of the "R" point shown in figure 1 (b) shall be assumed to be 500 mm above the floor under the passengers' feet, 300 mm from the inside surface of the side of the vehicle and 100 mm in front of the seat back in the centre line of the outboard seats.

8. INTERPRETATION OF TEST RESULTS

- 8.1. If body sections are tested, the technical service responsible for conducting the test shall ensure that the vehicle complies with the conditions specified in appendix 2 of annex 5 to this Regulation which contains requirements for the distribution of the main energy absorbing parts of the superstructure of a vehicle.

9. MODIFICATIONS OF THE VEHICLE TYPE AND EXTENSION OF APPROVAL

- 9.1. Every modification of the vehicle type shall be notified to the administrative department which granted the type approval. The department may then either:
 - 9.1.1. consider that the modifications made are unlikely to have an appreciable adverse effect and that in any case the vehicle still complies with the requirements; or
 - 9.1.2. require a further test report from the technical service responsible for conducting the tests.
- 9.2. Confirmation or refusal of approval, specifying the alterations, shall be notified by the procedure specified in paragraph 4.3. above to the Parties to the Agreement which apply this Regulation.
- 9.3. The competent authority issuing the extension of approval shall assign a series number to each communication form drawn up for such an extension.

Figure 1

Residual Space

(All dimensions in millimetres)

1 (a) Laterally

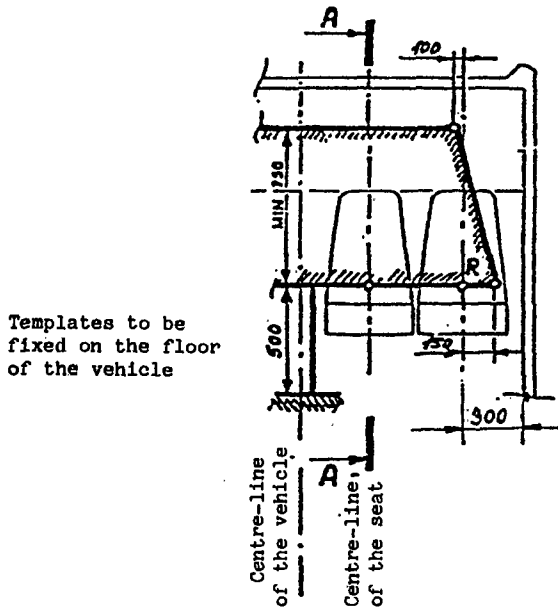

1 (b) Longitudinally Section A-A of the vehicle in the vertical plane of the centre-line of the inboard seats.

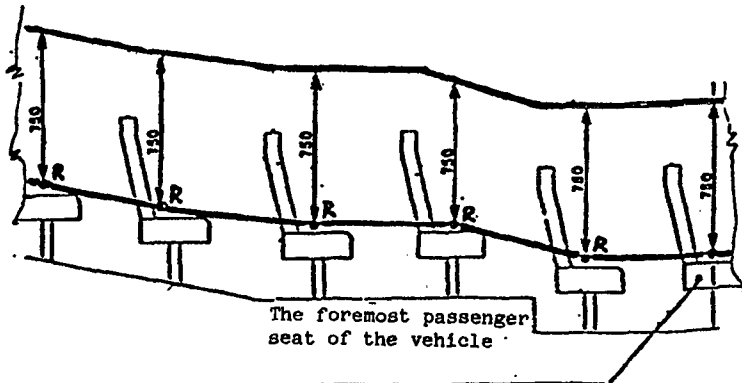

Note: See requirements of paragraph 7.2 of the Regulation.

10. CONFORMITY OF PRODUCTION

- 10.1. Vehicles approved in accordance with this Regulation shall be so manufactured as to conform to the type approved by meeting the requirements set out in paragraph 5 above.
- 10.2. To verify that conformity, suitable controls of the production shall be carried out. In this case suitable controls means checking the dimensions of the product as well as the existence of procedures for the effective control of the quality of products.
- 10.3. The holder of the approval shall in particular:
 - 10.3.1. have access to control equipment necessary for checking the conformity to each approved type,
 - 10.3.2. ensure that data of test results are recorded and that annexed documents shall remain available for a period to be determined in accordance with the administrative service, and
 - 10.3.3. analyse the results of each type of test, in order to verify and ensure the stability of the product characteristics, making allowance for variation of an industrial production.
- 10.4. The competent authority which has granted type-approval may at any time verify the conformity control methods applicable to each production unit.
- 10.5. The normal frequency of inspections authorized by the competent authority shall be one per year. In the case where negative results are recorded during one of these visits, the competent authority shall ensure that all necessary steps are taken to re-establish the conformity of production as rapidly as possible.

11. PENALTIES FOR NON-CONFORMITY OF PRODUCTION

- 11.1. The approval granted in respect of a vehicle type pursuant to this Regulation may be withdrawn if the requirements laid down in paragraph 10.1. above are not complied with.
- 11.2. If a party to the Agreement applying this Regulation withdraws an approval it has previously granted, it shall forthwith so notify the other Contracting Parties applying this Regulation, by means of a copy of the approval form bearing at the end, in large letters, the signed and dated annotation "APPROVAL WITHDRAWN".

12. PRODUCTION DEFINITELY DISCONTINUED

If the holder of the approval completely ceases to manufacture a type of vehicle approved in accordance with this Regulation, he shall so inform the authority which granted the approval. Upon receiving the relevant communication, that authority shall inform thereof the other Parties to the Agreement applying this Regulation by means of a copy of the approval form bearing at the end, in large letters, the signed and dated annotation "PRODUCTION DISCONTINUED".

13. NAMES AND ADDRESSES OF TECHNICAL SERVICES RESPONSIBLE FOR CONDUCTING APPROVAL TESTS, AND OF ADMINISTRATIVE DEPARTMENTS

The Parties to the Agreement which apply this Regulation shall communicate to the United Nations Secretariat the names and addresses of the technical services responsible for conducting approval tests and of the administrative departments which grant approval and to which forms certifying approval or extension or refusal or withdrawal of approval, issued in other countries, are to be sent.

ANNEX 1

(Maximum format: A 4 (210 × 2977 mm))



Communication concerning: approval
refusal of approval
extension of approval
withdrawal of approval
production definitely discontinued⁽²⁾

of a vehicle type with regard to the strength of its superstructure pursuant to Regulation No. 66

- Approval No. Extension No.
1. Trade name or mark of the vehicle.....
 2. Vehicle type.....
 3. Manufacturer's name and address.....
 4. If applicable, name and address of the manufacturer's representative
 5. Brief description of the superstructure of the vehicle type including dimensions, configuration and constituent materials and its attachment to any chassis frame
.....
 6. The position of the centre of gravity of the unladen vehicle in the longitudinal, transverse and vertical directions
 -
 7. Unladen kerb mass (kg)
 8. Vehicle submitted for approval on
 9. Method of test or calculation employed for approval.....
 10. Technical service responsible for conducting approval tests.....
 11. Date of test report issued by that service
 12. Number of report issued by that service
 13. Approval granted/refused/extended/withdrawn²
 14. Reason(s) of extension (if applicable).....
 15. Position of approval mark on the vehicle
 16. The documents with data, specified in paragraphs 3.2.1., 3.2.2. and 3.2.3., bearing the approval number shown above, deposited with the competent authority, are available on request.

Place:
Date:
Signature:

⁽¹⁾ Name of administration.
⁽²⁾ Strike out what does not apply.

ANNEX 2

ARRANGEMENT OF THE APPROVAL MARK

(see paragraph 4.4 of this Regulation)

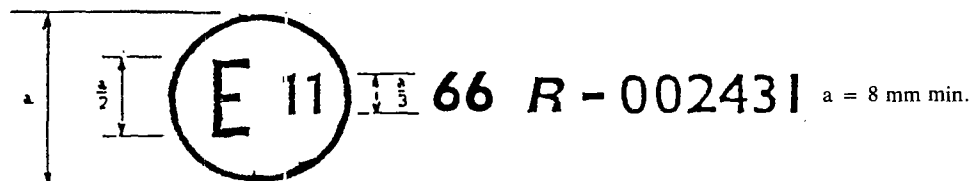

The above approval mark affixed to a vehicle shows that the vehicle type concerned has, with regard to the strength of the superstructure, been approved in the United Kingdom (E 11) pursuant to Regulation No. 66 under approval number 002431. The first two digits of the approval number indicate that the approval was granted in accordance with the requirements of Regulation No. 66 in its original form.

ANNEX 3

ROLL-OVER TEST ON A COMPLETE VEHICLE

1. TEST CONDITION
 - 1.1. While the vehicle need not be in a fully finished condition it shall be representative of production vehicles in respect of unladen kerb mass, centre of gravity and distribution of mass as declared by the manufacturer.
 - 1.2. Driver and passenger seats shall be placed with their backs, if adjustable, in their most upright position. The height of the seats, if adjustable, shall be the highest position.
 - 1.3. Every door and opening window of the vehicle shall be closed and latched but not locked. Windows and glazed bulkheads or screens may be glazed or unglazed at the applicant's discretion. If they are unglazed an equivalent weight shall be imposed on the vehicle at the appropriate positions.
 - 1.4. Tyres shall be inflated to the pressure prescribed by the vehicle manufacturer and, if the vehicle has an air-spring suspension system, the air supply to the air springs shall be ensured. Any automatic levelling system shall be adjusted with the vehicle on a flat, horizontal surface to the level specified by the manufacturer. Shock absorbers shall operate normally.
 - 1.5. Fuel, battery acid and other combustible, explosive or corrosive materials may be substituted by other materials provided that the conditions prescribed in paragraph 1.1 above are met.
 - 1.6. The impact area shall consist of concrete or other rigid material.
2. TEST PROCEDURE (See figure 1 of this annex)
 - 2.1. The vehicle shall be placed on a platform in order to be rolled over on one side. This side shall be specified by the manufacturer.

Figure 1

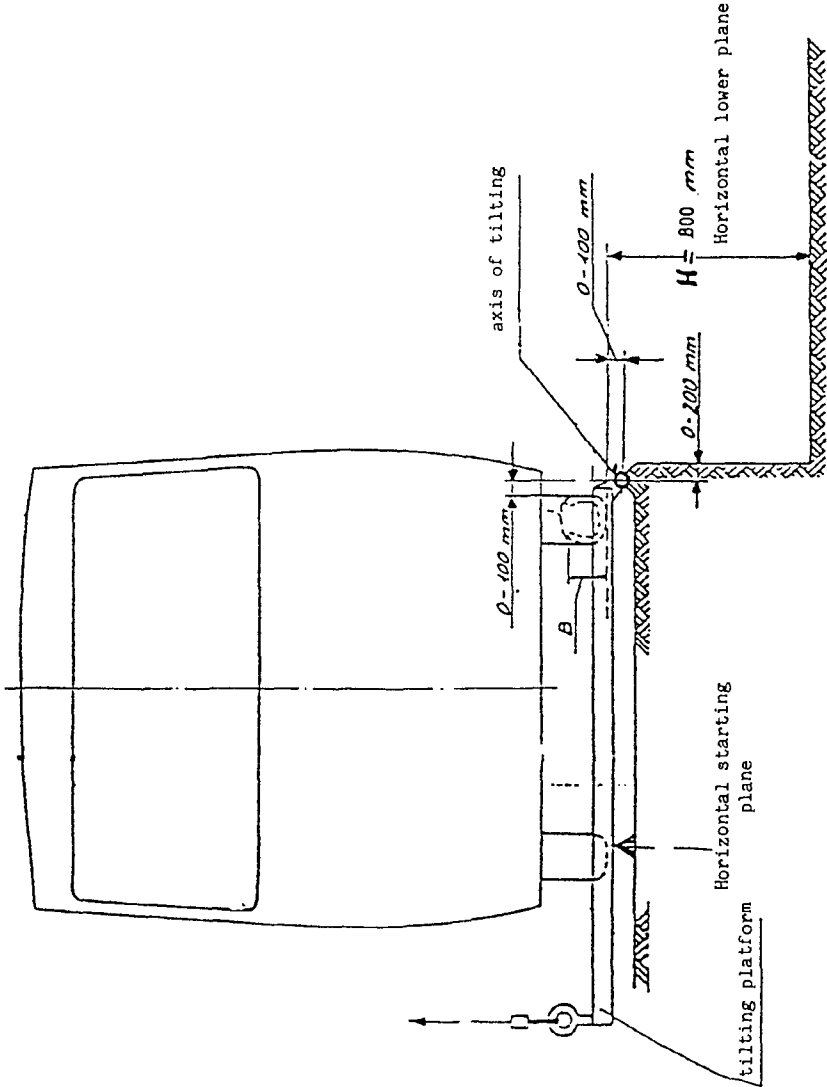

- 2.2. The position of the vehicle on the platform shall be such that when the platform is horizontal:
 - 2.2.1. the axis of rotation is parallel to the longitudinal axis of the vehicle,
 - 2.2.2. the axis of rotation is 0 – 200 mm from the vertical step between the two levels,
 - 2.2.3. the axis of rotation is 0 – 100 mm from the side of the tyre at the widest axle,
 - 2.2.4. the axis of rotation is 0 – 100 mm below the horizontal starting plane on which the tyres stand, and
 - 2.2.5. the difference between the height of the horizontal starting plane and the horizontal lower plane on which impact takes place shall be not less than 800 mm.
- 2.3. Means shall be provided to prevent the vehicle moving along its longitudinal axis.
- 2.4. The test apparatus shall prevent the tyres from sliding sideways in the direction of roll-over by means of side walls.
- 2.5. The test apparatus shall ensure the simultaneous lifting of the axles of the vehicle.
- 2.6. The vehicle shall be tilted without rocking and without dynamic effects until it rolls over. The angular velocity shall not exceed 5 degrees per second (0.087 rad/sec).
- 2.7. High-speed photography, deformable templates or other suitable means shall be used to determine that the requirement of paragraph 5.1 of this Regulation has been met. This shall be verified at not less than two positions, nominally at the front and rear of the passenger compartment, the exact positions being at the discretion of the technical service. Templates shall be fixed to substantially non-deformable parts of the structure.

ANNEX 4

ROLL-OVER TEST ON A BODY SECTION

1. TEST CONDITIONS
 - 1.1. The body section shall represent a section of the unladen vehicle.
 - 1.2. The geometry of the body section, the axis of rotation and the position of the centre of gravity in the vertical and lateral directions shall be representative of the complete vehicle.
 - 1.3. The mass of the body section, expressed as a percentage of the unladen kerb mass of the vehicle, shall be specified by the manufacturer.
 - 1.4. The energy to be absorbed by the body section, expressed as a percentage of the total energy which would be absorbed by a complete vehicle, shall be specified by the manufacturer.
 - 1.5. The percentage of total energy described in paragraph 1.4 shall not be less than the percentage of total kerb mass described in paragraph 1.3.
 - 1.6. The test conditions specified in paragraph 1.6 of annex 3 and in paragraphs 2.1 to 2.6 of annex 5 shall apply.
2. TEST PROCEDURE
 - 2.1. The test procedure shall be the same as the procedure described in annex 3, except that the body section described above shall be used instead of a complete vehicle.

ANNEX 5

PENDULUM TEST ON A BODY SECTION

1. ENERGY LEVEL AND DIRECTION OF IMPACT

- 1.1. The energy to be transmitted to a particular body section shall be the sum of the energies declared by the manufacturer to be allocated to each of the cross-sectional rings included in that particular body section.
- 1.2. The appropriate proportion of the energy prescribed in appendix 1 to this annex shall be applied to the body section by the pendulum such that at the moment of impact the direction of motion of the pendulum makes an angle of 25 degrees (+ 0°; - 5°) to the central longitudinal vertical plane of the body section. The precise angle within this range may be specified by the vehicle manufacturer.

2. TEST CONDITIONS

- 2.1. A sufficient number of tests shall be carried out for the technical service conducting the test to be satisfied that the requirement specified in paragraph 5.1 of this Regulation has been met.
- 2.2. For the purposes of the test body sections shall have sections of the normal structure fitted between the pillars in relation to the floor, underframe, sides and roof. Sections of such items as luggage racks, ventilation ducting etc., where fitted, shall also be included.
- 2.3. Every door and opening window of the body section shall be closed and latched but not locked. Windows and glazed bulkheads or screens may be glazed or unglazed at the applicant's discretion.
- 2.4. Where appropriate seats may also be included, at the option of the manufacturer, in their normal positions in relation to the structure of the body section. The normal fixings and joints between all members and attachments shall be incorporated. The backrests if adjustable shall be in their most upright position and the height of the seats if adjustable shall be the highest position.
- 2.5. The side of the body section to be impacted shall be at the discretion of the manufacturer. Where more than one body section is required to be tested both shall be impacted on the same side.
- 2.6. High speed photography, deformable templates or other suitable means shall be used to determine that the requirement specified in paragraph 5.1 of this Regulation has been met. Templates shall be fixed to a substantially non-deformable part of the structure.
- 2.7. The body section to be tested shall be firmly and securely attached to the mounting frame through the cross-bearers or parts which replace these in such a way that no significant energy is absorbed in the support frame and its attachments during the impact.
- 2.8. The pendulum shall be released from such a height that it strikes the body section at a speed of between 3 and 8 m/s.

3. DESCRIPTION OF THE PENDULUM

- 3.1. The striking face of the pendulum shall be made of steel, or plywood 20 mm ± 5 mm thick, and the mass of the pendulum shall be evenly distributed. Its striking face shall be rectangular and flat, having a width of not less than the width of the body section being tested and a height of not less than 800 mm. Its edges shall be rounded to a radius of curvature of not less than 15 mm.
- 3.2. The body of the pendulum shall be rigidly attached to two rigid bars. The axis of the bars shall be not less than 3,500 mm from the geometric centre of the body of the pendulum.

ANNEX 5 — APPENDIX 1

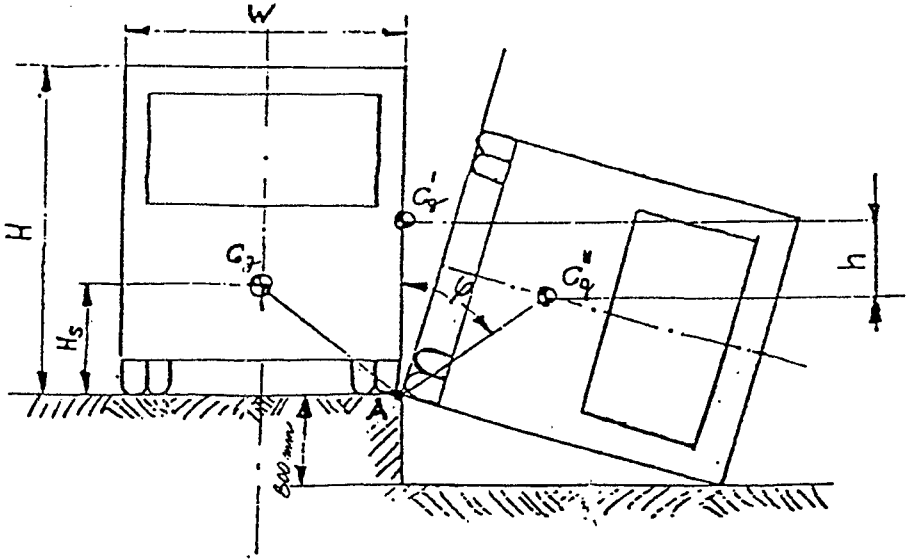
Calculation of total energy (E)**Assumptions*

1. The shape of the cross-section of the body is assumed to be rectangular.
2. The suspension system is assumed to be rigidly fixed.
3. The movement of the body section is assumed to be pure rotation about point "A".

Calculation of total energy (E)*

If the fall of the centre of gravity (h) is determined by graphical methods, E* may be taken to be given by the formula:

$$E^* = 0.75 M.g.h. \text{ (Nm)}$$

Alternatively, E* may be calculated by the formula:

$$E^* = 0.75 M.g. \left(\sqrt{\left(\frac{W}{2}\right)^2 + H_s^2} - \frac{W}{2H} \sqrt{H^2 - 0.8^2} + 0.8 \frac{H_s}{H} \right) \text{ (Nm)}$$

where:

M = the unladen kerb mass of the vehicle (kg)

g = 9.8 m/s²

W = the overall width of the vehicle (m)

H_s = the height of the centre of gravity of the unladen vehicle (m)

H = the height of the vehicle (m)

ANNEX 5 — APPENDIX 2

REQUIREMENTS FOR THE DISTRIBUTION OF THE MAIN ENERGY
ABSORBING PARTS OF THE SUPERSTRUCTURE

1. A sufficient number of tests shall be carried out for the technical service to be satisfied that the complete vehicle meets the requirements of paragraph 5.1 of this Regulation. This shall not necessarily require more than one test.
2. Calculations based on data obtained from a test on a body section may be used to demonstrate the acceptability of another body section which is not identical with the body section already tested if it has many structural features in common with it.
3. The manufacturer shall declare which pillars of the superstructure are considered as contributing to its strength and shall also declare the amount of energy (E_i) that each pillar is intended to absorb. These declarations shall meet the following criteria:

- (1) $\sum_{i=1}^{i=m} E_i \geq E^*$ Where m is the total number of declared pillars
- (2) (a) $\sum_{i=1}^{i=n} E_{iF} \geq 0.4 E^*$ Where n is the number of declared pillars forward of the centre of gravity of the vehicle
- (b) $\sum_{i=1}^{i=p} E_{iR} \geq 0.4 E^*$ Where p is the number of declared pillars to the rear of the centre of gravity of the vehicle
- (3) $L_F \geq 0.4 l_r$
- (4) $L_R \geq 0.4 l_r$
- (5) $\frac{d_{\max}}{d_{\min}} \leq 2.5$ This shall apply only where d_{\max} is greater than $0.8 \times$ maximum deflection permitted without intrusion of the residual space.

Where E_i is the declared amount of energy that can be absorbed by i^{th} pillar of the superstructure.

E_{iF} is the declared amount of energy that can be absorbed by the i^{th} pillar forward of the centre of gravity of the vehicle.

E_{iR} is the declared amount of energy that can be absorbed by the i^{th} pillar to the rear of the centre of gravity of the vehicle.

E^* is the total energy to be absorbed by the complete structure of the vehicle.

d_{\max} is the greatest amount of deflection measured in the direction of impact of any section of the body structure after it has absorbed its own declared impact energy.

d_{\min} is the least amount of deflection, measured in the direction of impact and at the same point on the bay as d_{\max} , of any section of the body structure after it has absorbed its own declared impact energy.

$$L_F = \frac{\sum_{i=1}^{i=n} (E_{iF} l_{if})}{\sum_{i=1}^{i=n} E_{iF}} = \text{Weighted mean distance of the declared pillars in front of the centre of gravity of the vehicle.}$$

$$L_R = \frac{\sum_{i=1}^{i=p} (E_{iR} l_{iR})}{\sum_{i=1}^{i=p} E_{iR}} = \text{Weighted mean distance of the declared pillars to the rear of the centre of gravity of the vehicle.}$$

Where l_{if} is the distance from the centre of gravity of the vehicle of the i^{th} pillar forward of the centre of gravity.

l_{iR} is the distance from the centre of gravity of the vehicle of the i^{th} pillar rearward of the centre of gravity.

l_f is the distance of the front of the vehicle from the centre of gravity of the vehicle.

l_r is the distance of the rear of the vehicle from the centre of gravity of the vehicle.

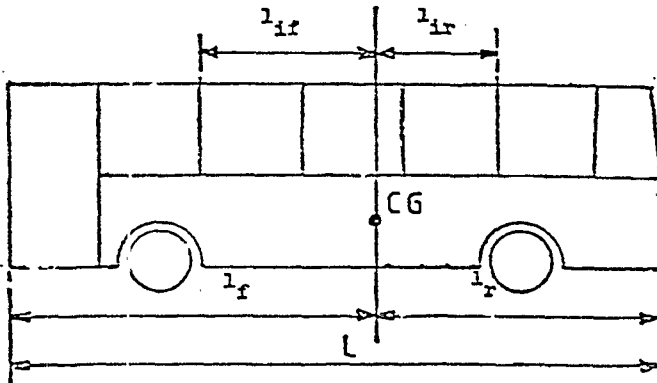

ANNEX 6

VERIFICATION OF STRENGTH OF SUPERSTRUCTURE BY CALCULATION

1. A superstructure or sections of a superstructure may be shown to meet the requirement specified in paragraph 5.1 of this Regulation by a calculation method approved by the technical service responsible for conducting the tests.
2. If the structure is likely to be subject to deformations beyond the elastic limit of the materials used then the calculations shall simulate the behaviour of the structure when undergoing large plastic deformations.
3. The technical service responsible for conducting the tests may require tests to be carried out on joints or parts of the structure to verify the assumptions made in the calculation.
4. PREPARATIONS FOR CALCULATION
 - 4.1. Calculations cannot be started until the structure has been analysed and a mathematical model of it produced. This will define the separate members to be considered and identify the points at which plastic hinges may develop. The

dimensions of the members and the properties of material used must be stated. Physical tests must be made on the hinge points to determine the force (moment of rotation) — deformation characteristics in the plastic mode as this is essential data for the calculations. The strain rate and the dynamic yield stress appropriate for this strain rate must be determined. If the calculation method will not indicate when a significant fracture will occur it will be essential to determine, by experiment, separate analyses or appropriate dynamic tests that significant fractures will not occur. The assumed distribution of loading along the length of a vehicle shall be stated.

- 4.2. The calculation method shall include the deformations up to the elastic limits of the materials followed by the identification of where plastic hinges will form and the subsequent formation of other plastic hinges unless the position and sequence of formation of plastic hinges is known from previous experience. The method shall accommodate the changes of geometry of the structure that take place, at least up to the stage where the deformations have passed the acceptable limits. The calculations shall simulate the energy and the direction of impact which would occur if that particular superstructure were to be submitted to the roll-over tests prescribed in annex 3. The validity of the calculation method shall have been established by comparison with the results of physical tests, which need not necessarily have been made in connection with the vehicle now being approved.

TESTS OF SECTIONS OF SUPERSTRUCTURE

5. When a calculation method is used for a section of the complete superstructure, the same conditions shall apply as stated above for the complete vehicle.

Authentic texts: English and French.

Registered ex officio on 1 December 1986.
