

10/325

UNITED NATIONS  NATIONS UNIES

(XI.B.16)

POSTAL ADDRESS—ADRESSE POSTALE UNITED NATIONS, N.Y. 10017
CABLE ADDRESS—ADRESSE TELEGRAPHIQUE UNATIONS NEWYORK

REFERENCE. C.N.260.1998.TREATIES-65 (Depositary Notification)

AGREEMENT CONCERNING THE ADOPTION OF UNIFORM TECHNICAL
PRESCRIPTIONS FOR WHEELED VEHICLES, EQUIPMENT AND PARTS WHICH
CAN BE FITTED AND/OR BE USED ON WHEELED VEHICLES AND THE
CONDITIONS FOR RECIPROCAL RECOGNITION OF APPROVALS GRANTED ON
THE BASIS OF THESE PRESCRIPTIONS
DONE AT GENEVA ON 20 MARCH 1958

AMENDMENTS PROPOSED TO REGULATION NO. 16

The Secretary-General of the United Nations, acting in his capacity as depositary, communicates the following:

On 16 June 1998, the Secretary-General received from the Administrative Committee of the above Agreement, pursuant to article 12 (1) of the Agreement, amendments proposed to Regulation No. 16 ("Uniform provisions concerning the approval of safety-belts and restraint systems for adult occupants of power-driven vehicles") annexed to the Agreement.

..... A copy, in the English and French languages, of the document containing the text of the proposed amendments is transmitted herewith (supplement 8 to the 04 series: doc. TRANS/WP.29/616).

The Secretary-General wishes to draw attention to article 12 (2) and (3) of the Agreement which read as follows:

"2. An amendment to a Regulation will be considered to be adopted unless, within a period of six months from its notification by the Secretary-General, more than one-third of the Contracting Parties applying the Regulation at the time of notification have informed the Secretary-General of their disagreement with the amendment. If, after this period, the Secretary-General has not received declarations of disagreement of more than one-third of the Contracting Parties applying the Regulation, the Secretary-General shall as soon as possible declare the amendment as adopted and binding upon those Contracting Parties applying the Regulation who did not declare themselves opposed to it. When a Regulation is amended and at least one-fifth of the Contracting Parties applying the unamended Regulation subsequently declare that they wish to continue to apply the unamended Regulation, the unamended Regulation will be regarded as an alternative to the amended Regulation and will be incorporated formally as such into the Regulation with effect from the date of adoption of the amendment or its entry into force. In this case the obligations of the Contracting Parties applying the Regulation shall be the same as set out in paragraph 1.

Attention: Treaty Services of Ministries of Foreign Affairs and of international organizations concerned



3. Should a new Contracting Party accede to this Agreement between the time of the notification of the amendment to a Regulation by the Secretary-General and its entry into force, the Regulation in question shall not enter into force for that Contracting Party until two months after it has formally accepted the amendment or two months after the lapse of a period of six months since the communication to that Party by the Secretary-General of the proposed amendment."

4 August 1998

A handwritten signature in black ink, appearing to be the initials 'GJ' or similar, written in a cursive style.



**Economic and Social
Council**

Distr.
GENERAL

TRANS/WP.29/616
15 May 1998

ENGLISH
Original: ENGLISH
and FRENCH

ECONOMIC COMMISSION FOR EUROPE

INLAND TRANSPORT COMMITTEE

Working Party on the Construction of Vehicles

**DRAFT SUPPLEMENT 8 TO THE 04 SERIES OF AMENDMENTS
TO REGULATION No. 16**

(Safety-belts)

Note: The text reproduced below was adopted by the Administrative Committee (AC.1) of the amended 1958 Agreement at its eighth session, following the recommendation by the Working Party at its one-hundred-and-fourteenth session. It is based on documents TRANS/WP.29/1997/6 and Add.1 as corrected (TRANS/WP.29/609, paras. 62 and 113).

The title of the Regulation, amend to read:

"UNIFORM PROVISIONS CONCERNING THE APPROVAL OF:

- I. SAFETY-BELTS AND RESTRAINT SYSTEMS FOR OCCUPANTS OF POWER-DRIVEN VEHICLES
- II. VEHICLES EQUIPPED WITH SAFETY-BELTS"

Paragraph 1., amend to read:

"1. Scope

This Regulation applies to safety-belts and restraint systems for installation in power-driven vehicles with three or more wheels and intended for separate use, i.e. as individual equipment, by person occupying forward or rearward-facing seats and also to vehicles equipped with such safety-belts."

Insert a new paragraph 2.18.1., to read:

"2.18.1. "A front passenger seat" means any seat where the "foremost H-point" of the seat in question is in or in front of the vertical transverse plane through the drivers R-point."

Insert new paragraphs 3.1. to 3.1.3., to read:

"3.1. Vehicle type"

3.1.1. The application for approval of a vehicle type with regard to the installation of its safety-belts and restraint systems shall be submitted by the vehicle manufacturer or by his duly accredited representative."

3.1.2. It shall be accompanied by the undermentioned documents in triplicate and the following particulars:

3.1.2.1. Drawings of the general vehicle structure on an appropriate scale, showing the positions of the safety-belts, and detailed drawings of the safety-belts and of the points to which they are attached;

3.1.2.2. A specification of the materials used which may affect the strength of the safety-belts;

3.1.2.3. A technical description of the safety-belts;

3.1.2.4. In the case of safety-belts affixed to the seat structure;

3.1.2.5. Detailed description of the vehicle type with regard to the design of the seats, of the seat anchorages and their adjustment and locking systems;

- 3.1.2.6. Drawings, on an appropriate scale and in sufficient detail, of the seats, of their anchorages to the vehicle, and of their adjustment and locking systems;
- 3.1.3. At the opinion of the manufacturer, a vehicle representative of the vehicle type to be approved or the parts of the vehicle considered essential for the safety-belt tests by the technical service conducting approval tests shall be submitted to the service."

Insert a new paragraph 3.2., to read:

"3.2. Safety-belt type"

Paragraphs 3.1. to 3.3. (former), renumber as paragraphs 3.2.1. to 3.2.3.

Paragraph 3.2.3.(former 3.3.), amend the reference to "paragraphs 3.2.2. and 3.2.3." to read "paragraphs 3.2.2.2. and 3.2.2.3."

Paragraph 4., amend the reference to "paragraphs 3.2.2., 3.2.3. and 3.2.4. to read "paragraphs 3.2.2.2., 3.2.2.3. and 3.2.2.4."

Insert new paragraphs 5.1.to 5.3., to read:

- "5.1. A certificate conforming to the model specified in paragraphs 5.1.1. or 5.1.2. shall be attached to the type-approval certificate:
- 5.1.1. Annex 1A for applications referred to in paragraph 3.1.;
- 5.1.2. Annex 1B for applications referred to in paragraph 3.2.;
- 5.2. Vehicle type
- 5.2.1. If the veicle is submitted for approval pursuant this Regulation meets the requirements of paragraph 8 below, and of annexes 15 and 16 to this Regulation, approval of that vehicle type shall be granted.
- 5.2.2. An approval number shall be assigned to each type approved. Its first two digits (at present 0.4) shall indicate the series of amendments incorporating the most recent major technical amendments made to the Regulation at the time of issue of the approval. The same Contracting Party shall not assign the same number to another vehicle type as defined in paragraph 2.16. above.

- 5.2.3. Notice of approval or of extension or refusal or withdrawal of approval or production definitely discontinued of a vehicle type pursuant to this Regulation shall be communicated to the Parties to the 1958 Agreement which apply this Regulation by means of a form conforming to the model in annex 1A to this Regulation.
- 5.2.4. There shall be affixed, conspicuously and in a readily accessible place specified on the approval form, to every vehicle conforming to a vehicle type approved under this Regulation an international approval mark consisting of:
- 5.2.4.1. a circle surrounding the letter "E" followed by the distinguishing number of the country which has granted approval; 1/
- 5.2.4.2. the number of this Regulation, followed by the letter R, a dash and the approval number to the right of the circle prescribed in paragraph 5.2.4.1.
- 5.2.5. If the vehicle conforms to a vehicle type approved, under one or more other Regulations annexed to the Agreement, in the country which has granted approval under this Regulation, the symbol prescribed in paragraph 5.2.4.1. need not be repeated; in such a case the additional numbers and symbols of all the Regulations under which approval has been granted in the country which has granted approval under this Regulation shall be placed in vertical columns to the right of the symbol prescribed in paragraph 5.2.4.1.
- 5.2.6. The approval mark shall be clearly legible and be indelible.
- 5.2.7. The approval mark shall be placed close to or on the vehicle data plate affixed by the manufacturer.

5.3. Safety-belt type"

Paragraphs 5.1. to 5.7. (former), renumber as paragraphs 5.3.1. to 5.3.7.

Paragraphs 5.3.1.(former 5.1.), amend the reference to paragraphs "3" and "5" to read paragraphs "3.2." and "5.3." respectively.

Paragraph 5.3.3.(former 5.3.), amend the reference to "annex 1" to read "annex 1B".

Paragraph 5.3.4.1.1. (former 5.4.1.1.), amend the reference to footnote "1/" to read "2/" and insert a new footnote 2/, to read:

"2/ See the footnote to paragraph 5.2.4.1."

1/ (Read footnote 1/ of the former paragraph 5.4.1.1., (not modified).)

Paragraph 5.3.4.2.2. (former 5.4.2.2.), amend the reference to "paragraph 5.4.2.1." to read paragraph 5.3.4.2.1".

Paragraph 5.3.4.2.2.2. (former 5.4.2.2.2.), amend the reference to "paragraph 2.9." to read "paragraph 2.14."

Paragraph 5.3.4.2.3. (former 5.4.2.3.), amend the reference to "paragraph 5.4.2.1." to read "paragraph 5.3.4.2.1."

Paragraph 5.3.5. (former 5.5.), amend to read:

"5.3.5. Annex 2, paragraph 2. to this Regulation gives..."

Paragraph 5.3.6. (former 5.6.), amend the reference to "paragraph 5.4." to read "paragraph 5.3.4."

Paragraph 5.3.7. (former 5.7.), amend the reference to "paragraph 5.6." to read "paragraph 5.3.6."

Paragraph 6.1.1., amend the reference to "paragraphs 3.2.2., 3.2.3. and 3.2.4." to read "paragraphs 3.2.2.2., 3.2.2.3. and 3.2.2.4."

Paragraph 6.4.1.2.4., should be deleted.

Paragraph 6.4.1.2.4.1., renumber as paragraph 6.4.1.2.4. and amend to read:

"6.4.1.2.4. In the case of safety-belt with a preloading device the minimum displacement specified in paragraph 6.4.1.3.2. below may be reduced by half. For the purpose of this test, the preloading device shall be in operation."

Paragraph 6.4.1.2.4.2., should be deleted.

Paragraph 7.9.1., should be deleted.

Paragraph 7.9.2., renumber as paragraph 7.9.1.

Insert new paragraphs 8. to 8.3.5., to read:

"8. REQUIREMENTS CONCERNING THE INSTALLATION IN THE VEHICLE

8.1. Vehicle equipment

8.1.1. "With the exception of folding seats (as defined in Regulation No. 14) and seating intended solely for use when the vehicle is stationary, the seats of vehicles of categories M and N as defined in annex 7 */ to the Consolidated Resolution (R.E.3) (except those vehicles in categories M₂ and M₃ which are designed for both urban use and standing passengers) must be equipped with safety-belts or restraint systems which satisfy the requirements of this Regulation.

*/ Document TRANS/WP.29/78/Rev.1

- 8.1.2. The types of safety-belts or restraint systems for each seating position where installation is required shall be those specified in annex 16 (with which neither non-locking retractors (para. 2.14.1.) nor manually unlocking retractor (para. 2.14.2.) can be used). For all seating positions where lap belts type B are specified in annex 16 lap belts type Br3 are permitted except in the case that, in use, they retract to such an extent as to reduce comfort in a notable way after normal buckling up.
- 8.1.3. However, for outboard seating positions, other than front, of vehicles of the category M_1 shown in annex 16 and marked with the symbol \emptyset , the installation of a lap belt of type Br4m is allowed, where there exists a passage between a seat and the nearest side wall of the vehicle intended to permit access of passengers to other parts of the vehicle. A space between a seat and the side wall is considered as a passage, if the distance between that side wall, with all doors closed, and a vertical longitudinal plane passing through the center line of the seat concerned - measured at the R-point position and perpendicularly to the median longitudinal plane of the vehicle - is more than 500 mm.
- 8.1.4. Where no safety-belts are required any type of safety-belt or restraint system conforming to this Regulation may be provided at the choice of the manufacturer. A-type belts of the types permitted in annex 16 may be provided as an alternative to lap belts for those seating positions where lap belts are specified in annex 16.
- 8.1.5. On three point belts fitted with retractors, one retractor must operate at least on the diagonal strap.
- 8.1.6. Except for vehicles of category M_1 an emergency locking retractor of type 4N (para. 2.14.5.) may be permitted instead of a retractor of type 4 (para. 2.14.4.) where it has been shown to the satisfaction of the services responsible for the tests that the fitting of a type 4 retractor would not be practical.
- 8.1.7. For the front outboard and the front centre seating positions shown in annex 16 and marked with the symbol *, lap belts of the type specified on that Annex shall be considered adequate where the windscreen is located outside the reference zone defined in annex 1 to Regulation No. 21.
- As regards safety-belts, the windscreen is considered as part of the reference zone when it is capable of entering into static contact with the test apparatus according to the method described in annex 1 of Regulation No. 21.
- 8.1.8. For all seating positions in annex 16 marked with the symbol #, lap belts of the types specified in annex 16 must be provided where an "exposed seating position" as defined in paragraph 8.1.9. exists.

- 8.1.9. An "exposed seating position" is one where there is no "protective screen" in front of the seat within the following defined space:
- 8.1.9.1. Between two horizontal planes, one through the H-point and the other 400 mm above it,
- 8.1.9.2. Between two vertical longitudinal planes which are symmetrical in relation to the H-point and are 400 mm apart,
- 8.1.9.3. Behind a transverse vertical plane 1.30 m from the H-point.

For the purposes of this requirement "protective screen" means a surface of suitable strength and showing no discontinuities such that, if a sphere of 165 mm diameter is geometrically projected in a longitudinal horizontal direction through any point of the space defined above and through the centre of the sphere, nowhere in the protective screen is there any aperture through which the geometrical projection of the sphere could be passed.

A seat is considered to be "an exposed seating position", if the protective screens within the space defined above have a combined surface area of less than 800 cm².

- 8.1.10. Every seating position in annex 16 marked with the symbol ★, three-point belts of a type specified in annex 16 shall be provided unless one of the following conditions is fulfilled, in which case two-point belts of a type specified in annex 16 may be provided.
- 8.1.10.1. There is a seat or other vehicle parts conforming to paragraph 3.5. of appendix 1 to Regulation No. 80 directly in front, or
- 8.1.10.2. No part of the vehicle is in or, when the vehicle is in motion, capable of being in the reference zone, or
- 8.1.10.3. Parts of the vehicle within the said reference zone comply with the energy absorbing requirements set out in appendix 6 of Regulation No. 80.
- 8.1.11. With the exception of the case covered by paragraph 8.1.12., every passenger seating position which is fitted with an airbag shall be provided with a warning against the use of a rearward-facing child restraint in that seating position. The warning label, in the form of a pictogram which may include explanatory text, shall be durably affixed and located such that it is easily visible in front of a person about to install a rearward-facing child restraint on the seat in question. An example of a possible design of a pictogram is shown in Figure 1. A permanent reference should be visible at all times, in case the warning is not visible when the door is closed.

Figure 1



Colours:

- o the pictogram is red
- o seat, child seat and contour line of the airbag are black
- o the word airbag as well as the airbag are white.

8.1.12 The requirements of paragraph 8.1.11. shall not apply if the vehicle is fitted with a mechanism which senses automatically the presence of any rearward-facing child restraint, and ensures that the airbag will not be deployed when such a child restraint system is fitted.

8.1.13 In the case of seats capable of being turned to or placed in other orientations, designed for use when the vehicle is stationary, the requirements of paragraph 8.1.1. shall only apply to those orientations designated for normal use when the vehicle is travelling on a road, in accordance with this Regulation.

8.2. General Requirements

8.2.1. Safety-belts and restraint systems shall be fixed to anchorages conforming to the specifications of Regulation No. 14.

8.2.2. The safety-belts and the restraint systems shall be so installed that, when properly worn, they will work satisfactorily and reduce the risk of bodily injury in the event of an accident. In particular they shall be so installed that:

8.2.2.1. The straps are not liable to assume a dangerous configuration;

8.2.2.2. That the danger of a correctly positioned belt slipping from the shoulder of a wearer as a result of his/her forward movement is reduced to a minimum.

8.2.2.3. The risk of the strap deteriorating through contact with sharp parts of the vehicle or seat structure is reduced to a minimum.

- 8.2.2.4. The design and installation of every safety-belt provided for each seating position shall be such as to be readily available for use. Furthermore, where the complete seat or the seat cushion and/or the seat back can be folded to permit access to rear of the vehicle or to goods or luggage compartment, after folding and restoring those seats to the seating position, the safety-belts provided for those seats shall be accessible for use or can be easily recovered from under or behind the seat, by one person, according to instructions in the vehicle users handbook, without the need for that person to have training or practice.
- 8.2.2.5. The technical service shall verify that, with the buckle tongue engaged in the buckle and no occupant in the seat:
- 8.2.2.5.1. The possible slack in the belt does not prevent the correct installation of child restraint systems recommended by the manufacturer, and
- 8.2.2.5.2. In the case of three-point belts, a tension of at least 50N can be established in the lap section of the belt by external application of tension in the diagonal section of the belt.
- 8.3. Special requirements for rigid parts incorporated in safety-belts or restraint systems
- 8.3.1. Rigid parts, such as the buckles, adjusting devices and attachments, shall not increase the risk of bodily injury to the wearer or to other occupants of the vehicle in the event of an accident.
- 8.3.2. The device for releasing the buckle shall be clearly visible to the wearer and within his easy reach and shall be so designed that it cannot be opened inadvertently or accidentally. The buckle shall also be located in such a position that it is readily accessible to a rescuer needing to release the wearer in an emergency.

The buckle shall be so installed that, both when not under load and when sustaining the wearer's mass, it is capable of being released by the wearer with a single simple movement of either hand in one direction.

In the case of a safety-belts or restraint systems for front outboard seating positions, except if these are harness belts, the buckle shall also be capable of being locked in the same manner.

A check shall be made to ensure that, if the buckle is in contact with the wearer, the width of the contact surface is not less than 46 mm.

A check shall be made to ensure that, if the buckle is in contact with the wearer, the contact surface satisfies the requirements of paragraph 6.2.2.1. of this Regulation.

- 8.3.3. When the belt is being worn, it shall either adjust automatically to fit the wearer or be so designed that the manual adjusting device is readily accessible to the wearer when seated and is convenient and easy to use. It shall also be possible for it to be tightened with one hand to suit the build of the wearer and the position of the vehicle seat.
- 8.3.4. Safety-belts or restraint systems incorporating retractors shall be so installed that the retractors are able to operate correctly and stow the strap efficiently.
- 8.3.5. In order to inform vehicle user(s) of the provisions made for the transport of children, vehicles of categories M₁ and N₁ shall meet the information requirements of annex 17."

Paragraph 8. (former), renumber as paragraph 9.

Paragraph 8.1. (former), renumber as paragraph 9.1., and amend to read:

- "9.1. Every vehicle type or safety-belt or restraint system approved under this Regulation shall be so manufactured as to conform to the type approved by meeting the requirements set forth in paragraphs 6, 7 and 8 above."

Paragraphs 8.2. and 8.3. (former), renumber as paragraphs 9.2. and 9.3.

Paragraphs 9. to 9.2 (former), renumber as paragraphs 10. to 10.2. and amend to read:

"10. PENALTIES FOR NON-CONFORMITY OF PRODUCTION

- 10.1. The approval granted in respect of a vehicle or a type of belt or restraint system may be withdrawn if the requirement laid down in paragraph 9.1. above is not complied with, or if the safety-belt(s) or restraint system(s) selected have failed to pass the checks prescribed in paragraph 9.2. above.
- 10.2. If a Contracting Party to the Agreement applying this Regulation withdraws an approval it has previously granted, it shall forthwith so notify the other Contracting Parties applying this Regulation by means of a communication form conforming to the model in annex 1A or annex 1B to this Regulation (as appropriate)."

Paragraphs 10. to 10.1.2., renumber as paragraphs 11. to 11.1.2. and amend to read:

- "11. MODIFICATIONS AND EXTENSION OF APPROVAL OF THE VEHICLE TYPE OR SAFETY-BELT OR RESTRAINT SYSTEM TYPE
- 11.1. Every modification of the vehicle type or the belt or restraint system or both shall be notified to the administrative department which approved the vehicle type or safety-belt or restraint system type. The department may then either:
- 11.1.1. Consider that the modifications made are unlikely to have an appreciable adverse effect and that in any case the vehicle or safety-belt or restraint system still complies with the requirements; or
- 11.1.2. Require a further test report from the technical service responsible for conducting the tests."

Insert a new paragraph 11.2., to read:

- "11.2. Without prejudice to the provisions of paragraph 11.1. above, a variant of the vehicle whose mass in the running order is less than that of the vehicle subjected to the approval test shall not be regarded as a modification of the vehicle type."

Paragraphs 10.2. and 10.3. (former), renumber as paragraphs 11.3. and 11.4., and amend to read:

- "11.3. Confirmation or refusal of approval, specifying the alterations, shall be communicated by the procedure specified in paragraph 5.2.3. or 5.3.3. above to the Parties to the Agreement applying this Regulation.
- 11.4. The competent authority issuing the extension of approval shall assign a series number for such an extension and inform thereof the other parties to the 1958 Agreement applying this Regulation by means of a communication form conforming to the model in annex 1A or 1B to this Regulation."

Paragraph 11. (former), renumber as paragraph 12. and amend to read:

"..... by means of a communication form conforming to the model in annex 1A or 1B to this Regulation."

Paragraph 12. (former), renumber as paragraph 13 and amend to read:

- "13. INSTRUCTIONS
- In the case of safety-belt type supplied separately from vehicle, the packaging and installation instructions must clearly state the vehicle type(s) for which it is intended."

Paragraph 13. (former), renumber as paragraph 14.

Insert a new paragraph 15., to read:

"15. TRANSITIONAL PROVISIONS

15.1. Approvals of vehicle type.

15.1.1. As from the official date of entry into force of the Supplement 8 to the 04 series of amendments, no Contracting Party applying this Regulation shall refuse to grant ECE approvals under this Regulation as modified by Supplement 8 to the 04 series of amendments.

Paragraphs 15.1.2. and 15.1.3 (new), amend to read:

15.1.2. As from 1 October 1999, Contracting Parties applying this Regulation shall grant ECE approvals only if the requirements of this Regulation, as amended by Supplement 8 to the 04 series of amendments, are satisfied.

15.1.3. As from 1 October 2001, Contracting Parties applying this Regulation may refuse to recognize approvals which were not granted in accordance with Supplement 8 to the 04 series of amendments to this Regulation.

15.1.3.1. However, as from 1 October 2000, for vehicles of categories M₁ and N₁, Contracting Parties applying this Regulation may refuse to recognize ECE approvals which were not granted in accordance with Supplement 8 to the 04 series of amendments to this Regulation, if the information requirements of paragraph 8.3.5. and annex 17 are not met."

Insert a new Annex 1A., to read:

"Annex 1A

(maximum format: A4 (210 x 297 mm))

COMMUNICATION



issued by: Name of administration:

.
.
.
.

- concerning: 2/ APPROVAL GRANTED
- APPROVAL EXTENDED
- APPROVAL REFUSED
- APPROVAL WITHDRAWN
- PRODUCTION DEFINITELY DISCONTINUED

of a vehicle type with regard to safety-belt pursuant to Regulation No.16

Approval No: Extension No:

- 1. General
- 1.1. Make (trade name of manufacturer):
- 1.2. Type and general commercial description(s):
- 1.3. Means of identification of type, if marked on the vehicle:
.
- 1.3.1. Location of that marking:
- 1.4. Category of vehicle:
- 1.5. Name and address of manufacturer:
- 1.6. Address(es) of assembly plant(s):

1/ Distinguishing number of the country which has granted/extended/refused/withdrawn approval (see approval provisions in the Regulation).

2/ Strike out what does not apply.

- 2. General construction characteristics of the vehicle
 - 2.1. Photographs and/or drawings of a representative vehicle:
- 3. Bodywork
 - 3.1. Seats
 - 3.1.1 Number:
 - 3.1.2 Position and arrangement:
 - 3.1.2.1. Seating position(s) designated for use only when the vehicle is stationary:
 - 3.1.3. Characteristics: description and drawings of
 - 3.1.3.1. the seats and their anchorages:
 - 3.1.3.2. the adjustment system:
 - 3.1.3.3. the displacement and locking systems:
 - 3.1.3.4. the seat belt anchorages if incorporated in the seat structure: .
 - 3.2. Safety-belts and/or other restraint systems
 - 3.2.1. Number and position of safety-belts and restraint systems and seats on which they can be used:

		Complete ECE type-approval mark	Variant (if applicable)	Belt adjustment device for height (indicate yes/no/optional)
First row of seat	R			
	C			
	L			
Second row of seat	R			
	C			
	L			
(R=right-hand seat, C=centre seat, L=left hand seat)				

3.2.2. Nature and position of supplementary restraint systems (indicate yes/no/optional).

		Front airbag	Side airbag	Belt preloading device
First row of seat	R			
	C			
	L			
Second row of seat	R			
	C			
	L			
(R=right-hand seat, C=centre seat, L=left hand seat)				

3.2.3. Number and position of safety-belt anchorages and proof of compliance with Regulation No. 14 (i.e. ECE type-approval number or test report).

4. Place
5. Date
6. Signature

_____ "

Annex 1(former), amend to read "Annex 1B".

Annex 2, insert at the beginning of the annex the following paragraph 1 (including models A and B of the approval marks):

"Annex 2

ARRANGEMENTS OF THE APPROVAL MARKS

1. Arrangements of the vehicle approval marks concerning the installation of safety-belts

Model A

(See paragraph 5.2.4. of this Regulation)

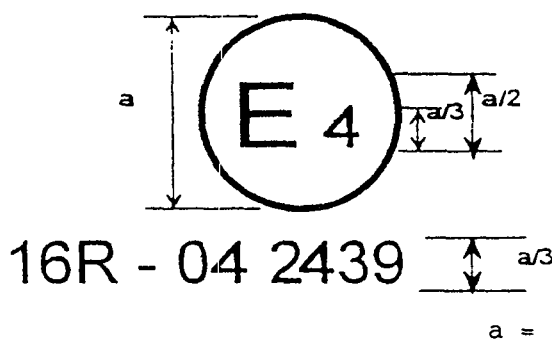

The above approval mark affixed to a vehicle shows that the vehicle type concerned has, with regard to safety-belts, been approved in the Netherlands (E4) pursuant to Regulation No. 16. The approval number indicates that the approval was granted according to the requirements of Regulation No. 16 as amended by the 04 series of amendments.

Model B

(See paragraph 5.2.5. of this Regulation)

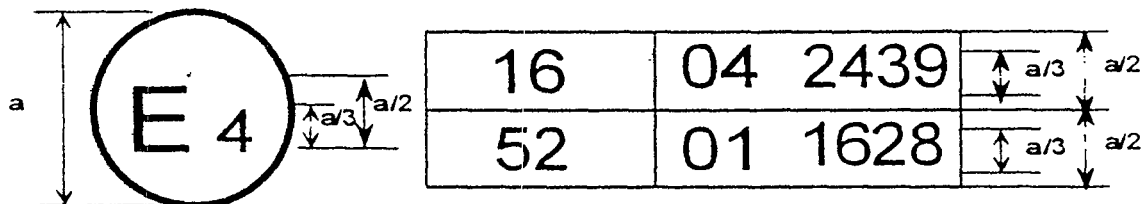

The above approval mark affixed to a vehicle shows that the vehicle type concerned has been approved in the Netherlands (E4) pursuant to Regulations Nos. 16 and 52. ^{1/} The approval numbers indicate that, at the dates when the respective approvals were given, Regulation No. 16 included the 04 series of amendments and Regulation No. 52 the 01 series of amendments."

^{1/} The second number is given merely as an example.

Annex 2, subsequently amend former Annex 2 (including five examples of approval marks) to read :

- "2. Arrangements of the safety-belt approval marks
(See paragraph 5.3.5 of this Regulation)

... This belt shall not be fitted to vehicles of category M₁.

_____ "

Insert a new Annex 15, to read:

"Annex 15

PROCEDURE FOR DETERMINING THE "H" POINT AND THE ACTUAL
TORSO ANGLE FOR SEATING POSITIONS IN MOTOR VEHICLES

1. PURPOSE

The procedure described in this annex is used to establish the "H" point location and the actual torso angle for one or several seating positions in a motor vehicle and to verify the relationship of measured data to design specifications given by the vehicle manufacturer. 1/

2. DEFINITIONS

For the purposes of this annex:

- 2.1. "Reference data" means one or several of the following characteristics of a seating position:
- 2.1.1. the "H" point and the "R" point and their relationship,
- 2.1.2. the actual torso angle and the design torso angle and their relationship.
- 2.2. "Three-dimensional 'H' point machine" (3-D H machine) means the device used for the determination of "H" points and actual torso angles. This device is described in appendix 1 to this annex;
- 2.3. "'H' point" means the pivot centre of the torso and the thigh of the 3-D H machine installed in the vehicle seat in accordance with paragraph 4 below. The "H" point is located in the centre of the centreline of the device which is between the "H" point sight buttons on either side of the 3-D H machine. The "H" point corresponds theoretically to the "R" point (for tolerances see paragraph 3.2.2. below). Once determined in accordance with the procedure described in paragraph 4, the "H" point is considered fixed in relation to the seat-cushion structure and to move with it when the seat is adjusted;

- 2.4. "'R' point" or "seating reference point" means a design point defined by the vehicle manufacturer for each seating position and established with respect to the three-dimensional reference system;
- 2.5. "Torso-line" means the centreline of the probe of the 3-D H machine with the probe in the fully rearward position;
- 2.6. "Actual torso angle" means the angle measured between a vertical line through the "H" point and the torso line using the back angle quadrant on the 3-D H machine. The actual torso angle corresponds theoretically to the design torso angle (for tolerances see paragraph 3.2.2. below):
- 2.7. "Design torso angle" means the angle measures between a vertical line through the "R" point and the torso line in a position which corresponds to the design position of the seat-back established by the vehicle manufacturer;
- 2.8. "Centreplane of occupant" (C/LO) means the median plane of the 3-D H machine positioned in each designated seating position; it is represented by the co-ordinate of the "H" point on the "Y" axis. For individual seats, the centreplane of the seat coincides with the centreplane of the occupant. For other seats, the centreplane of the occupant is specified by the manufacturer;
- 2.9. "Three-dimensional reference system" means a system as described in appendix 2 to this annex;
- 2.10. "Fiducial marks" are physical points (holes, surfaces, marks or indentations) on the vehicle body as defined by the manufacturer;
- 2.11. "Vehicle measuring attitude" means the position of the vehicle as defined by the co-ordinates of fiducial marks in the three-dimensional reference system.

3. REQUIREMENTS

3.1. Data presentation

For each seating position where reference data are required in order to demonstrate compliance with the provisions of the present Regulation, all or an appropriate selection of the following data shall be presented in the form indicated in appendix 3 to this annex:

- 3.1.1. the co-ordinates of the "R" point relative to the three-dimensional reference system;
- 3.1.2. the design torso angle;
- 3.1.3. all indications necessary to adjust the seat (if it is adjustable) to the measuring position set out in paragraph 4.3. below.

- 3.2. Relationship between measured data and design specifications
- 3.2.1. The co-ordinates of the "H" point and the value of the actual torso angle obtained by the procedure set out in paragraph 4. below shall be compared, respectively, with the co-ordinates of the "R" point and the value of the design torso angle indicated by the vehicle manufacturer.
- 3.2.2. The relative positions of the "R" point and the "H" point and the relationship between the design torso angle and the actual torso angle shall be considered satisfactory for the seating position in question if the "H" point, as defined by its co-ordinates, lies within a square of 50 mm side length with horizontal and vertical sides whose diagonals intersect at the "R" point, and if the actual torso angle is within 5° of the design torso angle.
- 3.2.3. If these conditions are met, the "R" point and the design torso angle, shall be used to demonstrate compliance with the provisions of this Regulation.
- 3.2.4. If the "H" point or the actual torso angle does not satisfy the requirements of paragraph 3.2.2. above, the "H" point and the actual torso angle shall be determined twice more (three times in all). If the results of two of these three operations satisfy the requirements, the conditions of paragraph 3.2.3. above shall apply.
- 3.2.5. If the results of at least two of the three operations described in paragraph 3.2.4. above do not satisfy the requirements of paragraph 3.2.2. above, or if the verification cannot take place because the vehicle manufacturer has failed to supply information regarding the position of the "R" point or regarding the design torso angle, the centroid of the three measured points or the average of the three measured angles shall be used and be regarded as applicable in all cases where the "R" point or the design torso angle is referred to in this Regulation.
4. PROCEDURE FOR "H" POINT AND ACTUAL TORSO ANGLE DETERMINATION
- 4.1. The vehicle shall be preconditioned at the manufacturer's discretion, at a temperature of $20 \pm 10^{\circ}\text{C}$ to ensure that the seat material reached room temperature. If the seat to be checked has never been sat upon, a 70 to 80 kg person or device shall sit on the seat twice for one minute to flex the cushion and back. At the manufacturer's request, all seat assemblies shall remain unloaded for a minimum period of 30 minutes prior to installation of the 3-D H machine.
- 4.2. The vehicle shall be at the measuring attitude defined in paragraph 2.11. above.

- 4.3. The seat, if it is adjustable, shall be adjusted first to the rearmost normal driving or riding position, as indicated by the vehicle manufacturer, taking into consideration only the longitudinal adjustment of the seat, excluding seat travel used for purposes other than normal driving or riding positions. Where other modes of seat adjustment exist (vertical, angular, seat-back, etc.) these will then be adjusted to the position specified by the vehicle manufacturer. For suspension seats, the vertical position shall be rigidly fixed corresponding to a normal driving position as specified by the manufacturer.
- 4.4. The area of the seating position contacted by the 3-D H machine shall be covered by a muslin cotton, of sufficient size and appropriate texture, described as a plain cotton fabric having 18.9 threads per cm² and weighing 0.228 kg/m² or knitted or non-woven fabric having equivalent characteristics. If the test is run on a seat outside the vehicle, the floor on which the seat is placed shall have the same essential characteristics 2/ as the floor of the vehicle in which the seat is intended to be used.
- 4.5. Place the seat and back assembly of the 3-D H machine so that the centreplane of the occupant (C/LO) coincides with the centreplane of the 3-D H machine. At the manufacturer's request, the 3-D H machine may be moved inboard with respect to the C/LO if the 3-D H machine is located so far outboard that the seat edge will not permit levelling of the 3-D H machine.
- 4.6. Attach the foot and lower leg assemblies to the seat pan assembly, either individually or by using the T-bar and lower leg assembly. A line through the "H" point sight buttons shall be parallel to the ground and perpendicular to the longitudinal centreplane of the seat.
- 4.7. Adjust the feet and leg positions of the 3-D H machine as follows:
- 4.7.1. Designated seating position: driver and outside front passenger
- 4.7.1.1. Both feet and leg assemblies shall be moved forward in such a way that the feet take up natural positions on the floor, between the operating pedals if necessary. Where possible the left foot shall be located approximately the same distance to the left of the centreplane of the 3-D H machine as the right foot is to the right. The spirit level verifying the transverse orientation of the 3-D H machine is brought to the horizontal by readjustment of the seat pan if necessary, or by adjusting the leg and foot assemblies towards the rear. The line passing through the "H" point sight buttons shall be maintained perpendicular to the longitudinal centreplane of the seat.
- 4.7.1.2. If the left leg cannot be kept parallel to the right leg and the left foot cannot be supported by the structure, move the left foot until it is supported. The alignment of the sight buttons shall be maintained.

4.7.2. Designated seating position: outboard rear

For rear seats or auxiliary seats, the legs are located as specified by the manufacturer. If the feet then rest on parts of the floor which are at different levels, the foot which first comes into contact with the front seat shall serve as a reference and the other foot shall be so arranged that the spirit level giving the transverse orientation of the seat of the device indicates the horizontal.

4.7.3. Other designated seating positions:

The general procedure indicated in paragraph 4.7.1. above shall be followed except that the feet shall be placed as specified by the vehicle manufacturer.

4.8. Apply lower leg and thigh weights and level the 3-D H machine.

4.9. Tilt the back pan forward against the forward stop and draw the 3-D H machine away from the seat-back using the T-bar. Reposition the 3-D H machine on the seat by one of the following methods:

4.9.1. If the 3-D H machine tends to slide rearward, use the following procedure. Allow the 3-D H machine to slide rearward until a forward horizontal restraining load on the T-bar is no longer required i.e. until the seat pan contacts the seat-back. If necessary, reposition the lower leg.

4.9.2. If the 3-D H machine does not tend to slide rearward, use the following procedure. Slide the 3-D H machine rearwards by applying a horizontal rearward load to the T-bar until the seat pan contacts the seat-back (see figure 2 of appendix 1 to this annex).

4.10. Apply a 100 ± 10 N load to the back and pan assembly of the 3-D H machine at the intersection of the hip angle quadrant and the T-bar housing. The direction of load application shall be maintained along a line passing by the above intersection to a point just above the thigh bar housing (see figure 2 of appendix 1 to this annex). Then carefully return the back pan to the seat-back. Care must be exercised throughout the remainder of the procedure to prevent the 3-D H machine from sliding forward.

4.11. Install the right and left buttock weights and then, alternately, the eight torso weights. Maintain the 3-D H machine level.

4.12. Tilt the back pan forward to release the tension on the seat-back. Rock the 3-D H machine from side to side through a 10° arc (5° to each side of the vertical centreplane) for three complete cycles to release any accumulated friction between the 3-D H machine and the seat.

During the rocking action, the T-bar of the 3-D H machine may tend to diverge from the specified horizontal and vertical alignment. The T-bar must therefore be restrained by applying an appropriate lateral load during the rocking motions. Care shall be exercised in holding the T-bar and rocking the 3-D H machine to ensure that no inadvertent exterior loads are applied in a vertical or fore and aft direction.

The feet of the 3-D H machine are not to be restrained or held during this step. If the feet change position, they should be allowed to remain in that attitude for the moment.

Carefully return the back pan to the seat-back and check the two spirit levels for zero position. If any movement of the feet has occurred during the rocking operation of the 3-D H machine, they must be repositioned as follows:

Alternately, lift each foot off the floor the minimum necessary amount until no additional foot movement is obtained. During this lifting, the feet are to be free to rotate; and no forward or lateral loads are to be applied. When each foot is placed back in the down position, the heel is to be in contact with the structure designed for this.

Check the lateral spirit level for zero position; if necessary, apply a lateral load to the top of the back pan sufficient to level the 3-D H machine's seat pan on the seat.

- 4.13. Holding the T-bar to prevent the 3-D H machine from sliding forward on the seat cushion, proceed as follows:
 - (a) return the back pan to the seat-back;
 - (b) alternately apply and release a horizontal rearward load, not to exceed 25 N, to the back angle bar at a height approximately at the centre of the torso weights until the hip angle quadrant indicates that a stable position has been reached after load release. Care shall be exercised to ensure that no exterior downward or lateral loads are applied to the 3-D H machine. If another level adjustment of the 3-D H machine is necessary, rotate the back pan forward, re-level, and repeat the procedure from paragraph 4.12.
- 4.14. Take all measurements:
 - 4.14.1. The co-ordinates of the "H" point are measured with respect to the three-dimensional reference system.
 - 4.14.2. The actual torso angle is read at the back angle quadrant of the 3-D H machine with the probe in its fully rearward position.

- 4.15. If a re-run of the installation of the 3-D H machine is desired the seat assembly should remain unloaded for a minimum period of 30 minutes prior to the re-run. The 3-D H machine should not be left loaded on the seat assembly longer than the time required to perform the test.
- 4.16. If the seats in the same row can be regarded as similar (bench seat, identical seats, etc.) only one "H" point and one "actual torso angle" shall be determined for each row of seats, the 3-D H machine described in appendix 1 to this annex being seated in a place regarded as representative for the row. This place shall be:
- 4.16.1. in the case of the front row, the driver's seat;
- 4.16.2. in the case of the rear row or rows, an outer seat.

-
- 1/ In any seating position other than front seats where the "H" point cannot be determined using the "Three-dimensional 'H' point machine" or procedures, the "R" point indicated by the manufacturer may be taken as a reference at the discretion of the competent authority.
- 2/ Tilt angle, height difference with a seat mounting, surface.

Annex 15 - Appendix 1

DESCRIPTION OF THE THREE DIMENSIONAL "H" POINT MACHINE */

(3-D H machine)

1. Back and seat pans

The back and seat pans are constructed of reinforced plastic and metal; they simulate the human torso and thigh and are mechanically hinged at the "H" point. A quadrant is fastened to the probe hinged at the "H" point to measure the actual torso angle. An adjustable thigh bar, attached to the seat pan, establishes the thigh centreline and serves as a baseline for the hip angle quadrant.

2. Body and leg elements

Lower leg segments are connected to the seat pan assembly at the T-bar joining the knees, which is a lateral extension of the adjustable thigh bar. Quadrants are incorporated in the lower leg segments to measure knee angles. Shoe and foot assemblies are calibrated to measure the foot angle. Two spirit levels orient the device in space. Body element weights are placed at the corresponding centres of gravity to provide seat penetration equivalent to a 76 kg male. All joints of the 3-D H machine should be checked for free movement without encountering noticeable friction.

*/ For details of the construction of the 3-D H machine refer to Society of Automobile Engineers (SAE), 400 Commonwealth Drive, Warrendale, Pennsylvania 15096, United States of America.

The machine corresponds to that described in ISO Standard 6549-1980.

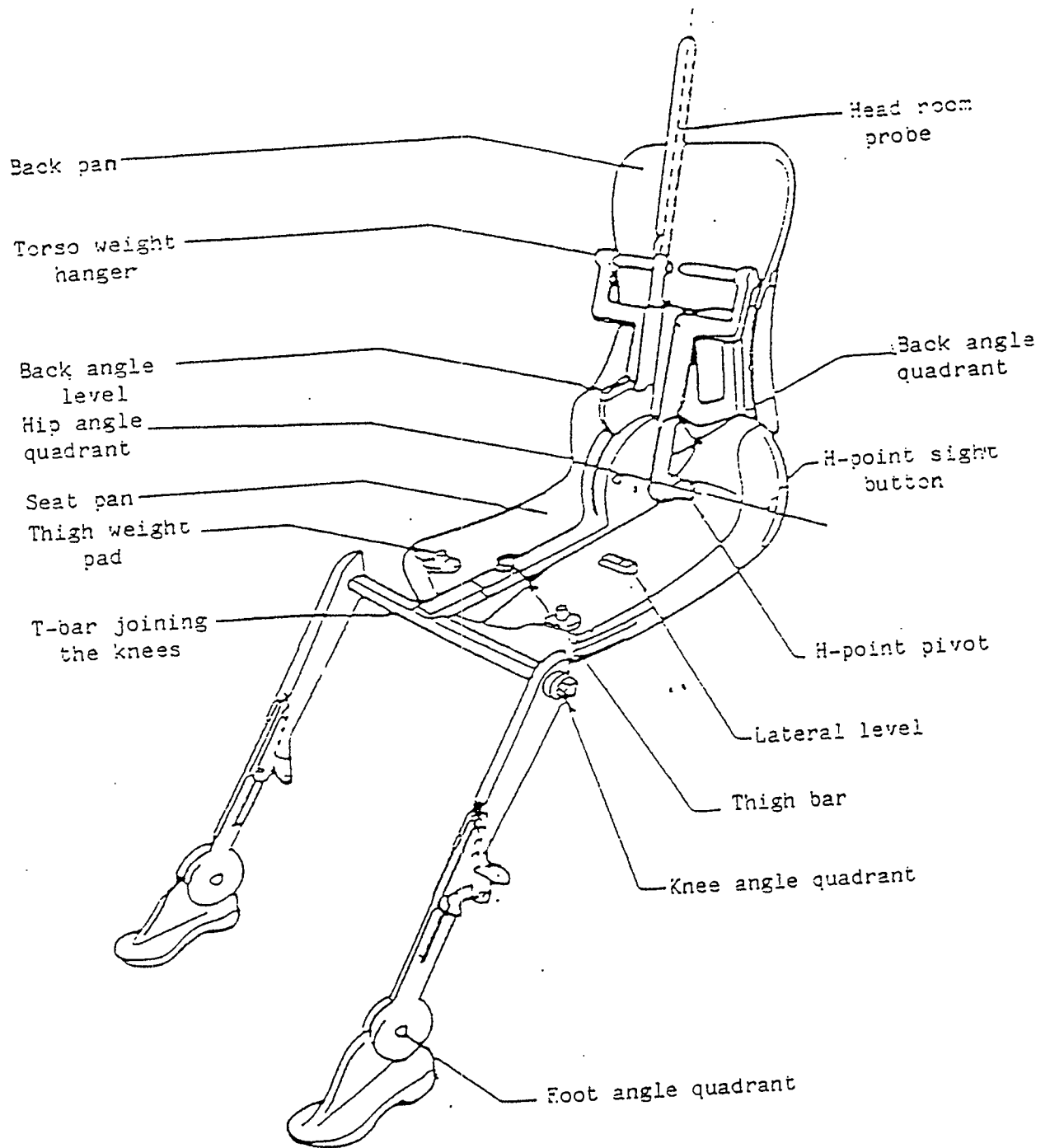

Figure 1 - 3-D H machine elements designation

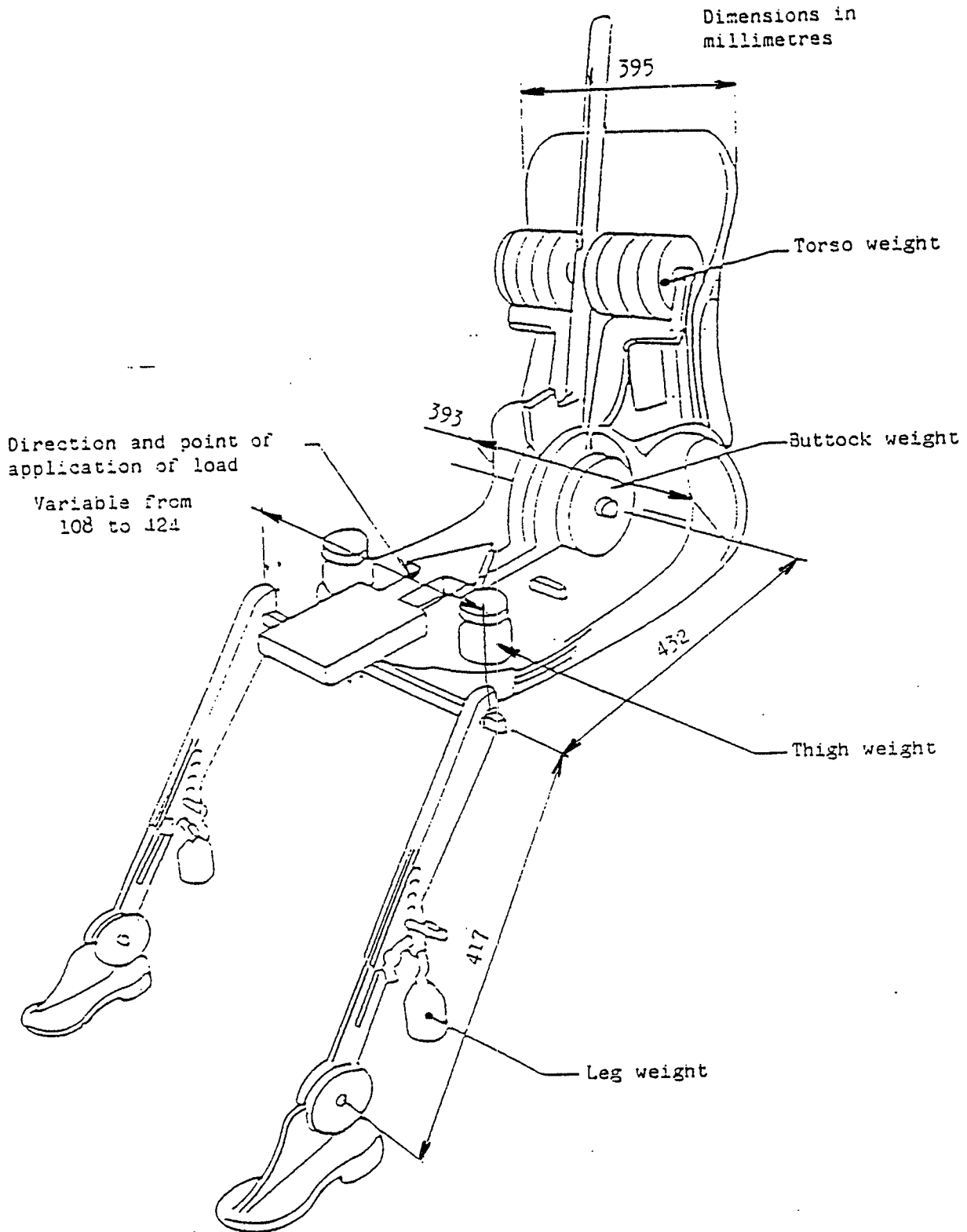

Figure 2 - Dimensions of the 3-D H machine elements and load distribution

Annex 15 - Appendix 2

THREE-DIMENSIONAL REFERENCE SYSTEM

1. The three-dimensional reference system is defined by three orthogonal planes established by the vehicle manufacturer (see figure). */
2. The vehicle measuring attitude is established by positioning the vehicle on the supporting surface such that the co-ordinates of the fiducial marks correspond to the values indicated by the manufacturer.
3. The co-ordinates of the "R" point and the "H" point are established in relation to the fiducial marks defined by the vehicle manufacturer.

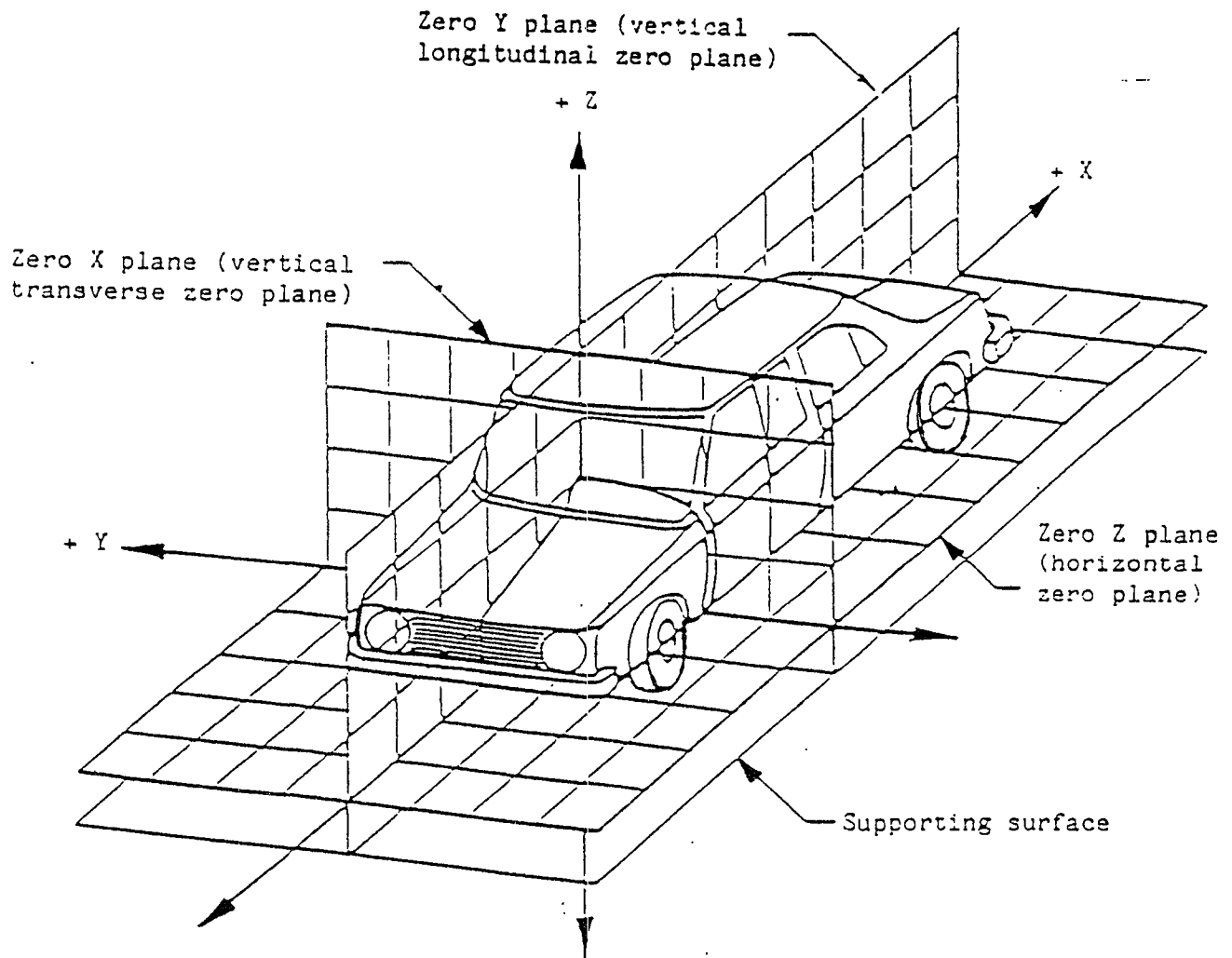

Figure - Three-dimensional reference system

*/ The reference system corresponds to ISO standard 4130, 1978.

Annex 15 - Appendix 3

REFERENCE DATA CONCERNING SEATING POSITIONS

1. Coding of reference data

Reference data are listed consecutively for each seating position. Seating positions are identified by a two-digit code. The first digit is an Arabic numeral and designates the row of seats, counting from the front to the rear of the vehicle. The second digit is a capital letter which designates the location of the seating position in a row, as viewed in the direction of forward motion of the vehicle; the following letters shall be used:

- L = left
- C = centre
- R = right

2. Description of vehicle measuring attitude

2.1. Co-ordinates of fiducial marks

- X
- Y
- Z

3. List of reference data

3.1. Seating position:

3.1.1. Co-ordinates of "R" point

- X
- Y
- Z

3.1.2. Design torso angle:

3.1.3. Specifications for seat adjustment */

- horizontal :
- vertical :
- angular :
- torso angle:

Note: List reference data for further seating positions under paragraphs 3.2., 3.3., etc.

*/ Strike out what does not apply."

Insert a new Annex 16, to read:

Annex 16: Safety-belt installation showing the belt types and retractor types

TABLE SHOWING MINIMUM REQUIREMENTS FOR SAFETY BELTS AND RETRACTORS					
VEHICLE CATEGORY	FORWARD FACING SEATING POSITIONS				REAR FACING SEATING POSITIONS
	OUTBOARD SEATING POSITIONS		CENTRE SEATING POSITIONS		
	FRONT	OTHER THAN FRONT	FRONT	OTHER THAN FRONT	
M1	Ar4m	Ar4m Br4m Ø	B, Br3, Br4m or A, Ar4m*	B, Br3, Br4m	B, Br3, Br4m
		Para. 8.1.3. lap belt permitted if seat is inboard of a passageway	Para. 8.1.7. lap belt permitted if the windscreen is not in the reference zone		
M2 ≤ 3.5 tonnes	Ar4m, Ar4Nm	Ar4m, Ar4Nm	Ar4m, Ar4Nm	Ar4m, Ar4Nm	Br3, Br4m, Br4Nm
M2 > 3.5 tonnes	Br3, Br4m, Br4Nm or Ar4m, Ar4Nm ★	Br3, Br4m, Br4Nm or Ar4m, Ar4Nm ★	Br3, Br4m, Br4Nm or Ar4m, Ar4Nm ★	Br3, Br4m, Br4Nm or Ar4m, Ar4Nm ★	Br3, Br4m, Br4Nm
M3	See para. 8.1.10 for conditions when a lap belt is permitted	See para. 8.1.10. for conditions when a lap belt is permitted	See para. 8.1.10. for conditions when a lap belt is permitted	See para. 8.1.10. for conditions when a lap belt is permitted	
N1	Ar4m, Ar4Nm	B, Br3, Br4m, Br4Nm or none #	B, Br3, Br4m, Br4Nm or A, Ar4m, Ar4Nm *	B, Br3, Br4m, Br4Nm or none #	None
		Para. 8.1.8. and 8.1.9. lap belt required in exposed seating positions	Para. 8.1.7. lap belt permitted if the windscreen is not in the reference zone	Para. 8.1.8. and 8.1.9. lap belt required in exposed seating positions	
N2	Br3, Br4m, Br4Nm or A, Ar4m, Ar4Nm*	B, Br3, Br4m, Br4Nm or none #	B, Br3, Br4m, Br4Nm or A, Ar4m, Ar4Nm*	B, Br3, Br4m, Br4Nm or none #	None
N3	Para. 8.1.7. lap belt permitted if the windscreen is outside the reference zone and for the driver's seat	Para. 8.1.8. and 8.1.9. lap belt required in exposed seating positions	Para. 8.1.7. lap belt permitted if the windscreen is not in the reference zone	Para. 8.1.8. and 8.1.9. lap belt required in exposed seating positions	

A: 3-point (lap and diagonal) belt

3: automatically locking retractor

*: Refers to para. 8.1.7. of this annex

B: 2-point (lap) belt

4: emergency locking retractor

#: Refers to paras. 8.1.8. and 8.1.9. of this annex

r: retractor

N: higher response threshold

Ø: Refers to para. 8.1.3. of this annex

m: emergency locking retractor with multiple sensitivity (see Regulation No. 16, paragraphs 2.14.3. to 2.14.5.)

★: Refers to para. 8.1.10. of this annex

Note: In all cases S-type belts may be fitted in place of an A or B type belt, provided anchorages complying with Regulation No. 14 are used.

Insert a new annex 17 and Appendices 1 and 2, to read:

"Annex 17

REQUIREMENTS FOR THE INSTALLATION
OF SAFETY-BELTS AND RESTRAINT SYSTEMS FOR ADULT OCCUPANTS
OF POWER-DRIVEN VEHICLES ON FORWARD FACING SEATS

1. Compatibility with child restraint systems

- 1.1. The vehicle manufacturer shall include in the vehicle handbook advice on the suitability of each passenger seat position for the carriage of children up to 12 years old (or up to 1.5 m tall), or the fitting of child restraint systems. This information shall be given in the national language, or at least one of the national languages, of the country in which the vehicle is offered for sale.

For each forward-facing passenger seat position, the manufacturer shall either:

- (a) Indicate that the seat position is suitable for child restraints of the "universal" category (see para. 1.2. below);
- (b) Provide a list of restraint systems of the "semi-universal", "restricted" or "vehicle-specific" categories, suitable for that vehicle seat position, indicating the mass group(s) for which the restraints are intended;
- (c) Provide a built-in child restraint, indicating the mass group(s) for which the restraint is intended and the corresponding configuration(s);
- (d) Provide any combination of (a), (b) and (c), or
- (e) Indicate the mass group(s) of the children which shall not be carried in that seat position.

If a seat position is only suitable for use with forward-facing child restraint systems, this shall be indicated.

A table in a suitable format for this information is given in appendix 2 to this annex.

- 1.2. A "universal" category child restraint means a child restraint approved to the "universal" category of ECE Regulation No. 44, 03 series of amendments. Seat positions which are indicated by the vehicle manufacturer as being suitable for the installation of child restraints of the "universal" category shall comply with the provisions of appendix 1 to this annex.

Annex 17 - Appendix 1

PROVISIONS CONCERNING THE INSTALLATION OF "UNIVERSAL"
CATEGORY CHILD RESTRAINT SYSTEMS INSTALLED WITH
THE SAFETY-BELT EQUIPMENT OF THE VEHICLE

1. General
 - 1.1. The test procedure and the requirements in this appendix shall be used to determine the suitability of seat positions for the installation of child restraints of the "universal" category.
 - 1.2. The tests may be carried out in the vehicle or in a representative part of the vehicle.
2. Test procedure
 - 2.1. Adjust the seat to its fully rearward and lowest position.
 - 2.2. Adjust the seat-back angle to the manufacturer's design position. In the absence of any specification, an angle of 25 degrees from the vertical, or the nearest fixed position of the seat-back, should be used.
 - 2.3. Set the shoulder anchorage to the lowest position.
 - 2.4. Place a cotton cloth on the seat-back and cushion.
 - 2.5. Place the fixture (as described in figure 1 of this appendix) on the vehicle seat.
 - 2.6. If the seating position is intended to accommodate a forward-facing or rearward-facing universal restraint system, proceed according to paragraphs 2.6.1., 2.7., 2.8., 2.9. and 2.10. If the seating position is intended to accommodate only a forward-facing universal restraint system, proceed according to paragraphs 2.6.2., 2.7., 2.8., 2.9. and 2.10.
 - 2.6.1. Arrange the safety belt strap around the fixture in approximately the correct position as shown in figures 2 and 3, then latch the buckle.
 - 2.6.2. Arrange the safety belt lap strap approximately in the correct position around the lower part of the fixture of 150 mm radius as shown in figure 3, then latch the buckle.
 - 2.7. Ensure that the fixture is located with its centreline on the apparent centreline of the seating position ± 25 mm with its centreline parallel with the centreline of the vehicle.
 - 2.8. Ensure that all webbing slack is removed. Use sufficient force to remove the slack, do not attempt to tension the webbing.
 - 2.9. Push rearwards on the centre of the front of the fixture with a force of $100 \text{ N} \pm 10 \text{ N}$, applied parallel to the lower surface, and remove the force.

- 2.10. Push vertically downwards on the centre of the upper surface of the fixture with a force of $100\text{ N} \pm 10\text{ N}$, and remove the force.

3. Requirements

- 3.1. The base of the fixture shall contact both the forward and rearward parts of the seat cushion surface. If such contact does not occur due to the belt access gap in the test fixture, this gap may be covered in line with the bottom surface of the test fixture.
- 3.2. The lap portion of the belt shall touch the fixture on both sides at the rear of the lap belt path (see figure 3).
- 3.3. Should the above requirements not be met with the adjustments indicated in paragraphs 2.1., 2.2. and 2.3., the seat, seat-back and safety belt anchorages may be adjusted to an alternative position designated by the manufacturer for normal use at which the above installation procedure shall be repeated and the requirements again verified and met.

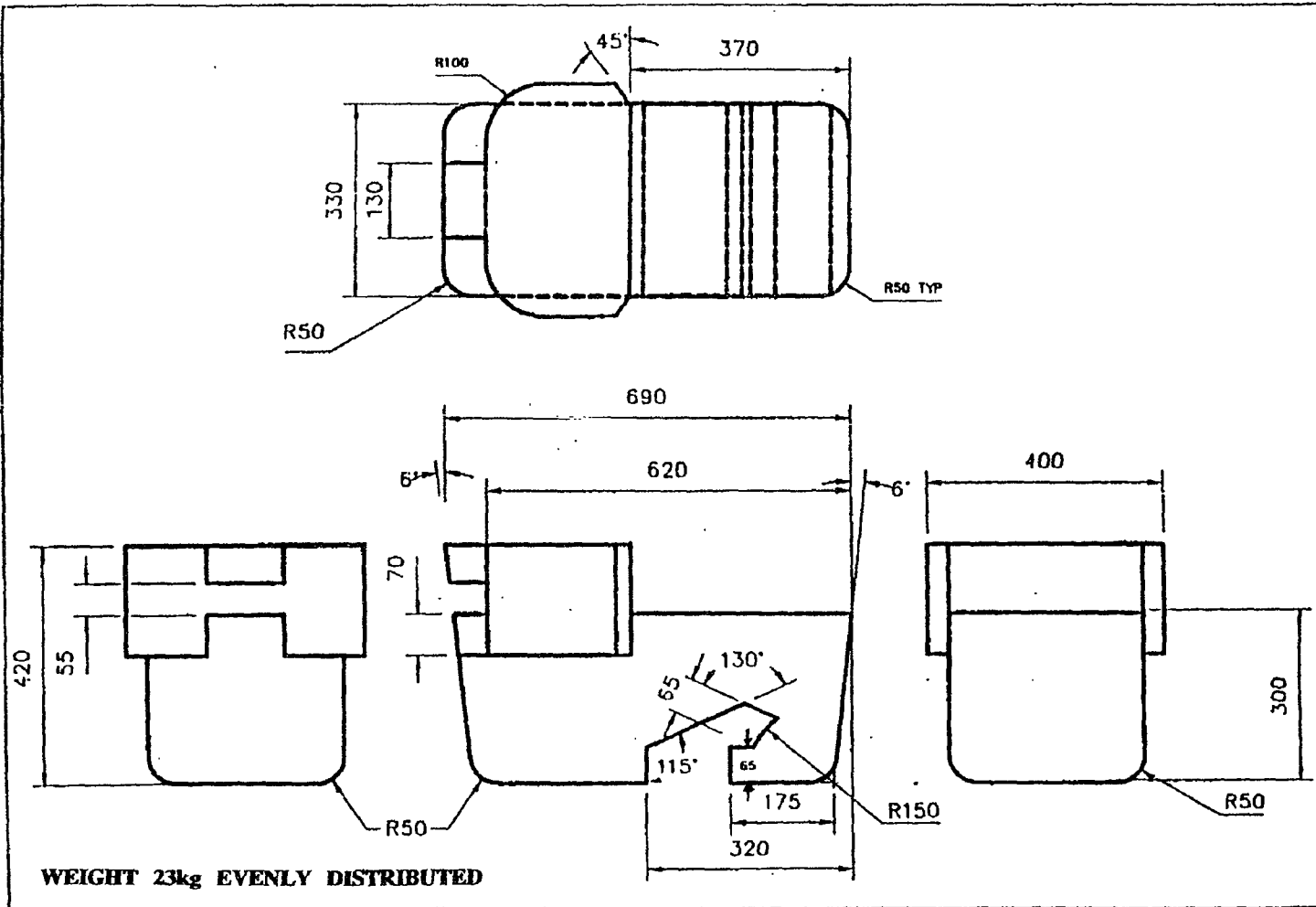

Figure 1: Specifications of the fixture

FIGURE 2
INSTALLATION OF FIXTURE ONTO VEHICLE SEAT
(see paragraph 2.6.1.)

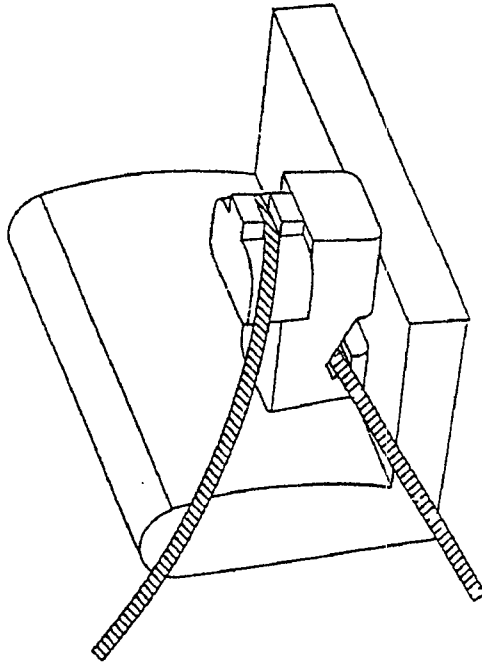
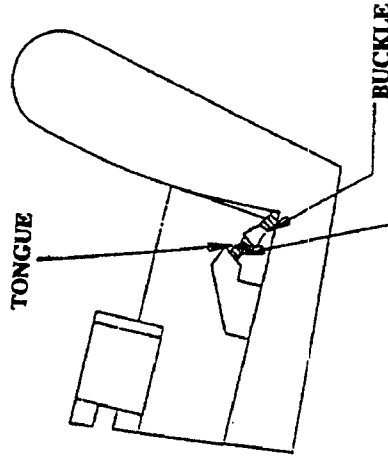

FIGURE 3
CHECK FOR COMPATIBILITY
(see paragraphs 2.6.1. and 3.2.)



Note: THE SEAT BELT WEBBING
MUST CONTACT THE CURVED EDGE
ON BOTH SIDES OF THE FIXTURE

LAP BELT ONLY SHOWN

Annex 17 - Appendix 2

TABLE OF VEHICLE HANDBOOK INFORMATION ON CHILD RESTRAINT
SUITABILITY FOR VARIOUS SEATING POSITIONS

Mass Group	Seating position				
	Front Passenger	Rear Outboard	Rear Centre	Intermediate Outboard	Intermediate Centre
0 - Up to 10 kg (0-9 months)					
0+ - Up to 13 kg (0-2 years)					
I - 9 to 18 kg (9 months - 4 years)					
II & III - 15 to 36 kg (4-12 years)					

Key of letters to be inserted in the above table:

U = Suitable for "universal" category restraints approved for use in this mass group.

UF = Suitable for forward-facing "universal" category restraints approved for use in this mass group.

L = Suitable for particular child restraints given on attached list. These restraints may be of the "specific vehicle", "restricted" or "semi-universal" categories.

B = Built-in restraint approved for this mass group.

X = Seat position not suitable for children in this mass group."