

98/529 (XI.B.16)

UNITED NATIONS  NATIONS UNIES

POSTAL ADDRESS—ADRESSE POSTALE: UNITED NATIONS, N.Y. 10017
CABLE ADDRESS—ADRESSE TELEGRAPHIQUE: UNATIONS NEWYORK

REFERENCE: C.N.257.1998.TREATIES-62 (Depositary Notification)

AGREEMENT CONCERNING THE ADOPTION OF UNIFORM TECHNICAL
PRESCRIPTIONS FOR WHEELED VEHICLES, EQUIPMENT AND PARTS WHICH
CAN BE FITTED AND/OR BE USED ON WHEELED VEHICLES AND THE
CONDITIONS FOR RECIPROCAL RECOGNITION OF APPROVALS GRANTED ON
THE BASIS OF THESE PRESCRIPTIONS
DONE AT GENEVA ON 20 MARCH 1958

AMENDMENTS PROPOSED TO REGULATION NO. 10

The Secretary-General of the United Nations, acting in his capacity as depositary, communicates the following:

On 16 June 1998, the Secretary-General received from the Administrative Committee of the above Agreement, pursuant to article 12 (1) of the Agreement, amendments proposed to Regulation No. 10 ("Uniform provisions concerning the approval of motor vehicles with regard to electromagnetic compatibility") annexed to the Agreement.

..... A copy, in the English and French languages, of the document containing the text of the proposed amendments is transmitted herewith (supplement 1 to the 02 series: doc. TRANS/WP.29/613).

The Secretary-General wishes to draw attention to article 12 (2) and (3) of the Agreement which read as follows:

"2. An amendment to a Regulation will be considered to be adopted unless, within a period of six months from its notification by the Secretary-General, more than one-third of the Contracting Parties applying the Regulation at the time of notification have informed the Secretary-General of their disagreement with the amendment. If, after this period, the Secretary-General has not received declarations of disagreement of more than one-third of the Contracting Parties applying the Regulation, the Secretary-General shall as soon as possible declare the amendment as adopted and binding upon those Contracting Parties applying the Regulation who did not declare themselves opposed to it. When a Regulation is amended and at least one-fifth of the Contracting Parties applying the unamended Regulation subsequently declare that they wish to continue to apply the unamended Regulation, the unamended Regulation will be regarded as an alternative to the amended Regulation and will be incorporated formally as such into the Regulation with effect from the date of adoption of the amendment or its entry into force. In this case the obligations of the Contracting Parties applying the Regulation shall be the same as set out in paragraph 1.

Attention: Treaty Services of Ministries of Foreign Affairs and of international organizations concerned



3. Should a new Contracting Party accede to this Agreement between the time of the notification of the amendment to a Regulation by the Secretary-General and its entry into force, the Regulation in question shall not enter into force for that Contracting Party until two months after it has formally accepted the amendment or two months after the lapse of a period of six months since the communication to that Party by the Secretary-General of the proposed amendment."

4 August 1998

A handwritten signature in black ink, appearing to be the initials 'GJ' followed by a flourish.



**Economic and Social
Council**

Distr.
GENERAL

TRANS/WP.29/613
11 May 1998

ENGLISH
Original: ENGLISH
and FRENCH

ECONOMIC COMMISSION FOR EUROPE

INLAND TRANSPORT COMMITTEE

Working Party on the Construction of Vehicles

**DRAFT SUPPLEMENT 1 TO THE 02 SERIES OF AMENDMENTS
TO REGULATION No. 10**

(Electro-magnetic compatibility)

Note: The text reproduced below was adopted by the Administrative Committee (AC.1) of the amended 1958 Agreement at its eighth session, following the recommendation by the Working Party at its one-hundred-and-fourteenth session. It is based on document TRANS/WP.29/1998/15, not amended (TRANS/WP.29/609, para. 110).

Paragraph 1, amend to read:

"... compatibility of L, M ..."

Paragraph 12.2., add at the end the following text:

"....

For vehicles of category L the provisions of this paragraph shall apply from 17 June 1999."

Paragraph 12.3, amend to read:

"...

For vehicles of category L the provisions of annexes 6 and 9 shall apply from 18 August 2000."

Paragraph 12.4, amend to read:

"...

For vehicles of category L, the provisions of this paragraph shall apply from 18 August 2004."

Paragraph 12.5., amend the words "the date mentioned" to read "the dates mentioned".

Annex 4,

[Note: Two new figures are inserted (Nos. 2 and 4), changing the numbering.]

Paragraph 3.1., amend to read:

"... (see Fig. 1 of appendix 1 to this annex). Alternatively, for L-category vehicles the test surface may be any location that fulfils the conditions shown in Figure 2 of appendix 1 to this annex."

Paragraph 3.2., amend to read:

"... shown in Figure 1 in appendix 1 to this annex. Where test surface fulfils the conditions stated in Figure 2 in appendix 1 to this annex, the measuring equipment must lie outside the part shown in this Figure 2. Other measuring antennae ..."

Paragraph 3.3., amend to read:

"... the dimensional requirements of Figures 1 and 2 in appendix 1 of this annex other than"

Paragraph 5.3., amend to read:

"... engine mid-point. (See Fig. 3 and 4 in appendix 1 to this annex)."

Paragraph 5.4., amend to read:

"... and vertical polarizations. (See Fig. 3 and 4 in appendix 1 to this annex.)"

Annex 4 - Appendix,

Insert a new Figure 2, to read:

"Figure 2

Clear horizontal surface free of electromagnetic reflection
Delimitation of the surface defined by an ellipse
(See CISPR 12, Edition 2)

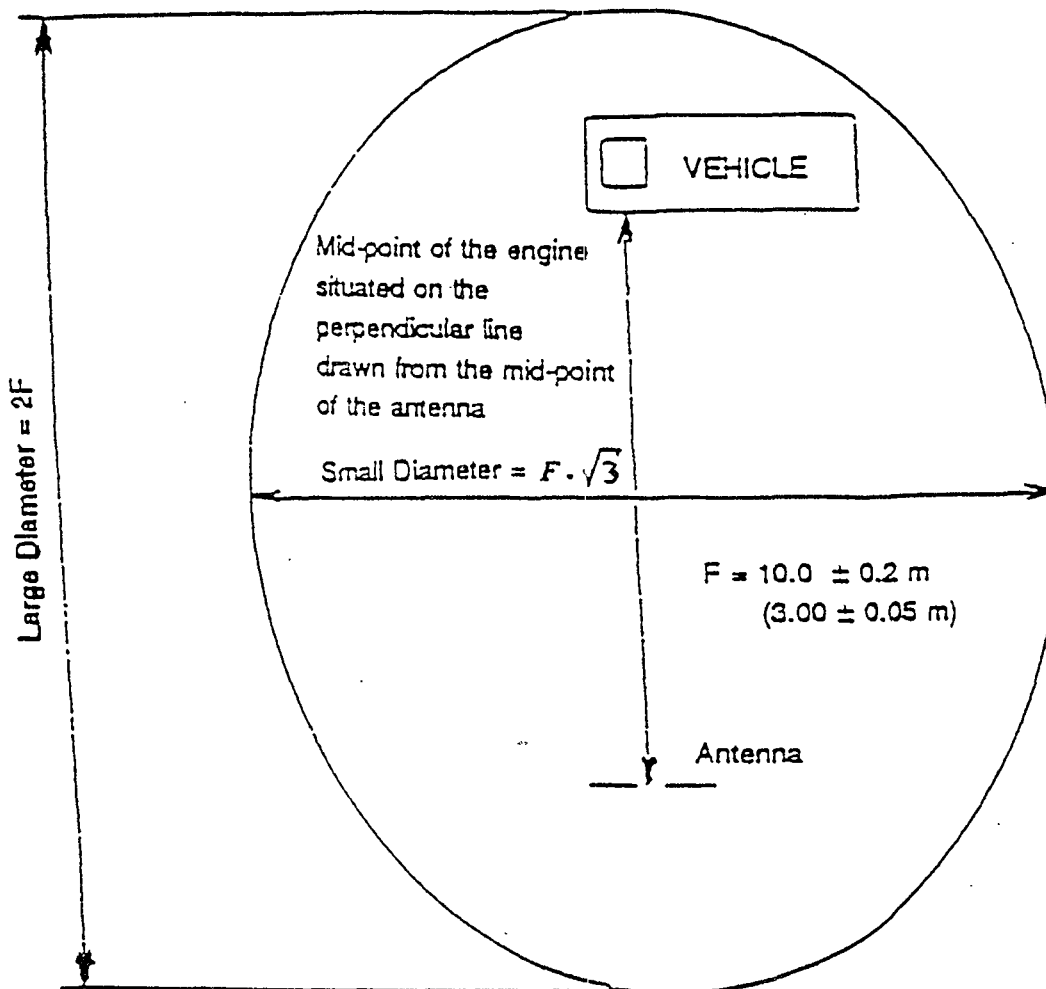
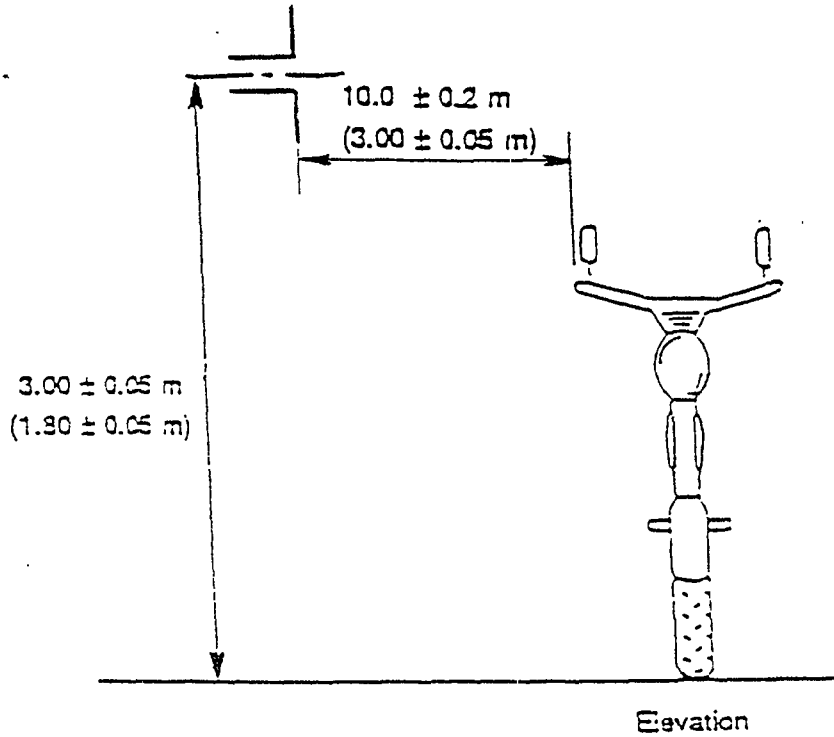

Figure 2 (former), renumber as Figure 3.

Insert a new figure 4, to read:

"Figure 4

Position of antenna in relation to the vehicle



Dipole antenna in position to measure the vertical radiation components

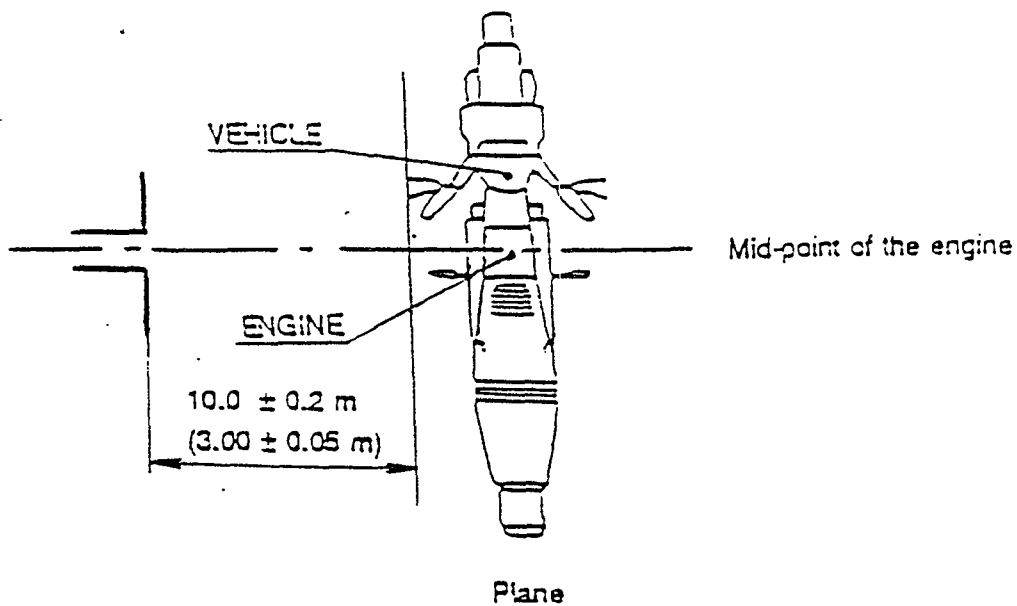

Dipole antenna in position to measure the horizontal radiation components

Annex 5,

Paragraphs 3, 3.1. and 3.2., amend the references to "Fig. 1 in appendix 1 to annex 4" to read "Figures 1 and 2 in appendix 1 to annex 4" (three times).

Paragraphs 5.3. and 5.4., amend the references to "Fig. 2 in appendix 1 to annex 4" to read "Figures 3 and 4 in appendix 1 to annex 4 as appropriate for the category of vehicle" (twice).

Annex 6,

[Note: Three new figures are inserted (Nos. 3, 4 and 6), changing the numbering.]

Paragraph 4.1.1., amend to read:

".... 50 km/h, or 25 km/h in the case of L1 and L2 vehicles, if there is no technical ..."

"... (e.g. trucks, two and three-wheeled vehicles)".

Paragraph 4.1.3., amend to read:

"...operating, if fitted,"

Paragraph 5.4.1.4., amend to read:

".... in a reference point closer to the antenna,

or:

at 1.0 ± 0.2 m behind the vertical centreline of the vehicle's front wheel (point C in appendix 3 to this annex) in the case of three-wheeled vehicles,

or:

at 0.2 ± 0.2 m behind the vertical centreline of the vehicle's front wheel (point D in appendix 4 to this annex) in the case of two-wheeled vehicles."

Paragraph 5.5., amend the reference to "appendix 3 to this annex" to read "appendices 5 and 6 to this annex as appropriate for the category of vehicle."

Paragraph 7.4.1., amend the reference to "appendix 4 to this annex" to read "appendix 7 to this annex."

Insert new appendices 3 and 4 to annex 6, to read:

"Annex 6 - Appendix 3

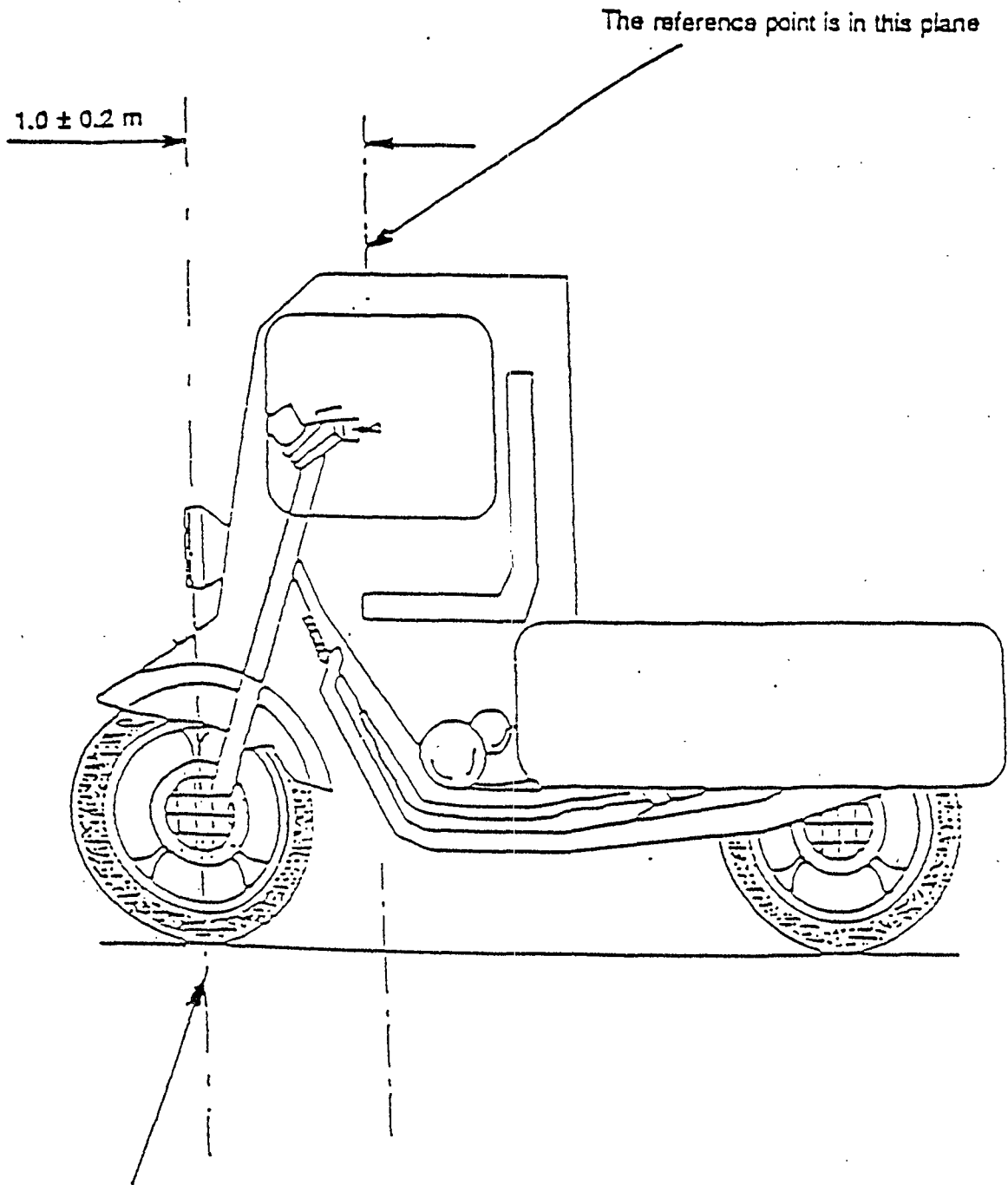

Vertical axis of the front wheel (point C)

Annex 6 - Appendix 4

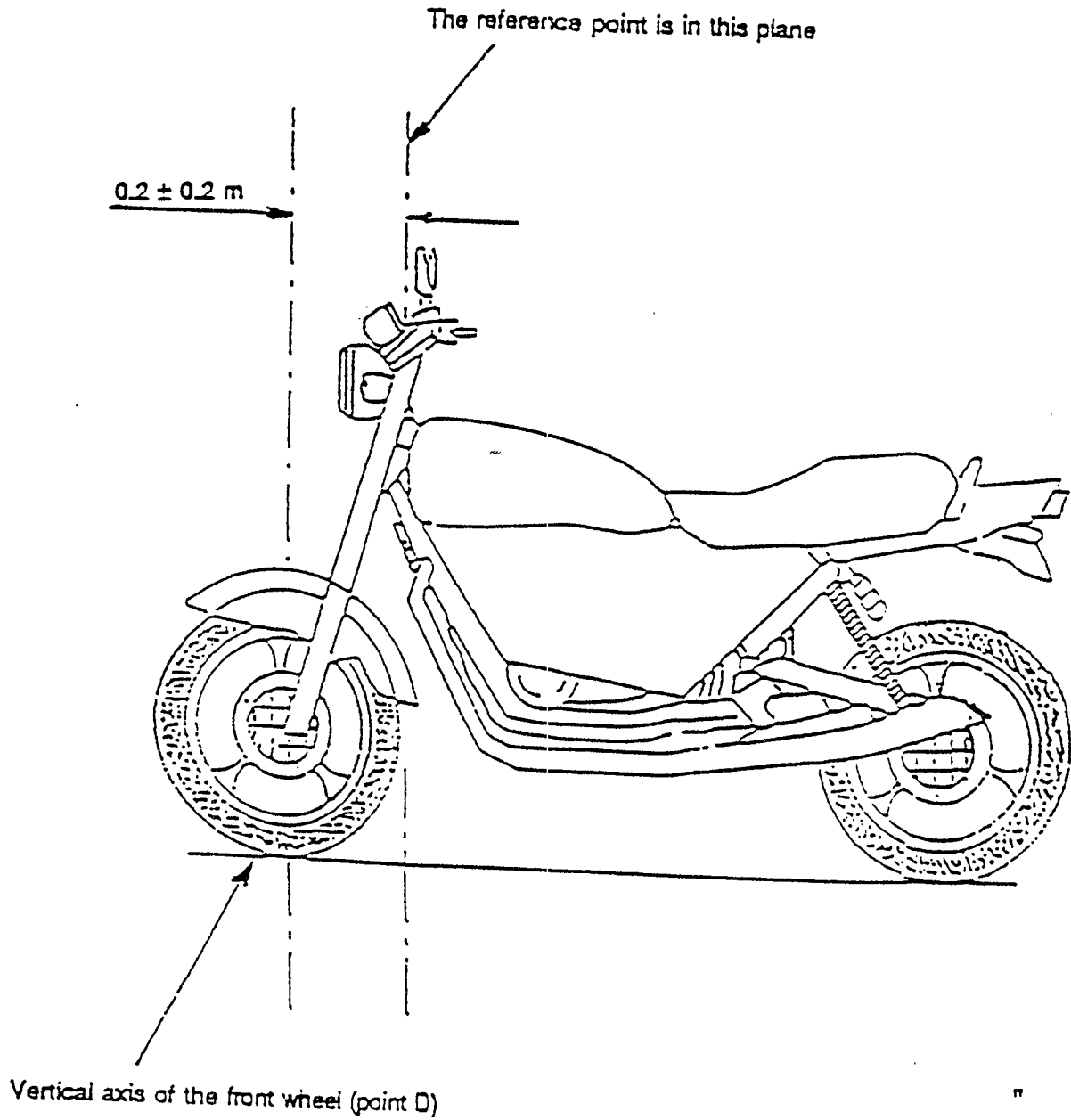

Annex 6 - Appendix 3 (former), renumber as "Annex 6 - Appendix 5".

Insert a new Annex 6 - Appendix 6, to read:

"Annex 6 - Appendix 6

First stage:
Determine the reference point

Second stage:
Rotate the vehicle

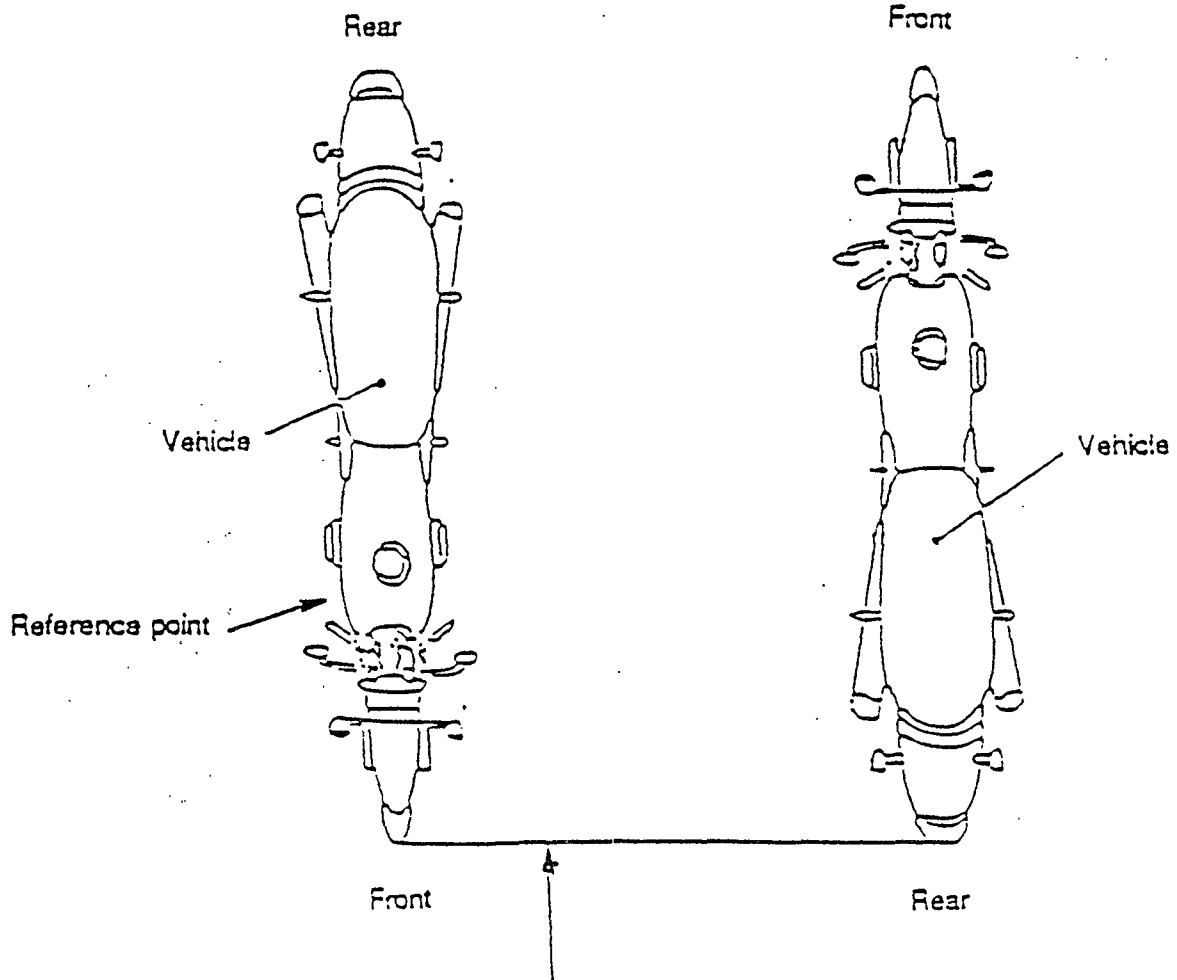

Distance maintained between the vehicle and antenna

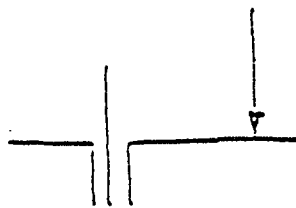

Antenna

Annex 6 - Appendix 4 (former), renumber as "Annex 6 - Appendix 7."