

UNITED NATIONS  NATIONS UNIES

POSTAL ADDRESS—ADRESSE POSTALE: UNITED NATIONS, N.Y. 10017  
CABLE ADDRESS—ADRESSE TELEGRAPHIQUE: UNATIONS NEWYORK

Reference: C.N.1188.1999.TREATIES-4 (Depositary Notification)

AGREEMENT CONCERNING THE ADOPTION OF UNIFORM CONDITIONS  
OF APPROVAL AND RECIPROCAL RECOGNITION OF APPROVAL FOR  
MOTOR VEHICLE EQUIPMENT AND PARTS. GENEVA, 20 MARCH 1958

REGULATION NO. 22. UNIFORM PROVISIONS CONCERNING THE  
APPROVAL OF PROTECTIVE HELMETS AND THEIR VISORS FOR DRIVERS  
AND PASSENGERS OF MOTOR CYCLES AND MOPEDS

PROPOSAL OF AMENDMENTS TO REGULATION

On 22 December 1999, the Secretary-General received from the Administrative Committee of the above Agreement, pursuant to article 12 (1) of the Agreement, amendments proposed to the above Regulation.

A copy, in the English and French languages, of the document containing the text of the proposed amendments is transmitted herewith (doc. TRANS/WP.29/694).

The Secretary-General wishes to draw attention to article 12 (2) and (3) of the Agreement which read as follows:

"2. An amendment to a Regulation will be considered to be adopted unless, within a period of six months from its notification by the Secretary-General, more than one-third of the Contracting Parties applying the Regulation at the time of notification have informed the Secretary-General of their disagreement with the amendment. If, after this period, the Secretary-General has not received declarations of disagreement of more than one-third of the Contracting Parties applying the Regulation, the Secretary-General shall as soon as possible declare the amendment as adopted and binding upon those Contracting Parties applying the Regulation who did not declare themselves opposed to it. When a Regulation is amended and at least one-fifth of the Contracting Parties applying the unamended Regulation subsequently declare that they wish to continue to apply the unamended Regulation, the unamended Regulation will be regarded as an alternative to the amended Regulation and will be incorporated formally as such into the Regulation with effect from the date of adoption of the amendment or its entry into force. In this case the obligations of the Contracting Parties applying the Regulation shall be the same as set out in paragraph 1.

Attention: Treaty Services of Ministries of Foreign Affairs and of international organizations concerned.

3. Should a new Contracting Party accede to this Agreement between the time of the notification of the amendment to a Regulation by the Secretary-General and its entry into force, the Regulation in question shall not enter into force for that Contracting Party until two months after it has formally accepted the amendment or two months after the lapse of a period of six months since the communication to that Party by the Secretary-General of the proposed amendment."

30 December 1999

A handwritten signature in black ink, appearing to be the initials 'M/V'.



**Economic and Social  
Council**

Distr.

GENERAL

TRANS/WP.29/694

3 December 1999

ENGLISH

Original: ENGLISH and  
FRENCH

---

**ECONOMIC COMMISSION FOR EUROPE**

INLAND TRANSPORT COMMITTEE

Working Party on the Construction of Vehicles

**DRAFT 05 SERIES OF AMENDMENTS TO REGULATION No. 22**  
(Protective helmets)

Note: The text reproduced below was adopted by the Administrative Committee (AC.1) of the amended 1958 Agreement at its thirteenth session, following the recommendation by the Working Party at its one-hundred-and-nineteenth session. It is based on document TRANS/WP.29/1999/39, as amended (TRANS/WP.29/689, para. 145).

The List of Contents,

Insert a new title of paragraph 9., to read:

"9. Product qualification"

Titles of paragraphs 9. to 13. (former), renumber as paragraphs 10. to 14.

Insert a new title of paragraph 15., to read:

"15. Transitional provisions"

Title of paragraph 14. (former), renumber as paragraph 16.

The List of Contents - annexes,

Insert titles of five new annexes, to read:

Annex 12 - Type approval scheme (Flow chart)

Annex 13 - Definitions

Annex 14 - Product of the spectral distribution of radiation of the signal light and standard illuminant D65

Annex 15 - Test of refractive powers

Annex 16 - Test for mist-retardant visors"

The text of the Regulation,

Paragraph 2.7., amend to read:

"2.7. "lower face cover" means a detachable, movable or integral (permanently fixed) part of the helmet covering the lower part of the face;"

Insert new paragraphs 2.7.1. and 2.7.2., to read:

"2.7.1. "protective lower face cover" means a detachable, movable or integral (permanently fixed) part of the helmet covering the lower part of the face and intended to protect the chin of the user against impacts;

"2.7.2. "non protective lower face cover" means a detachable or movable part of the helmet covering the lower part of the face that does not protect the chin of the user against impacts;"

Paragraph 2.8., amend to read:

". . . and covering all or part of the face;"

Insert new paragraphs 2.10. to 2.13., to read:

- "2.10.            Disposable protective film
- 2.10.1.        A removable plastic film may be applied to protect the visor prior to use. In this case the film has to be opaque or printed, so that it must be removed before use.
- 2.10.2.        A protective film (tear-off) may be used for racing for example to reduce the level of luminous transmission. Such tear-off-films are not for use on the road and are not covered by this Regulation.
- 2.11.            "ocular areas" means two circles of minimum diameter 52 mm spaced symmetrically about the vertical centre line of the visor, the distance between the centres of the circles being 64 mm measured in the horizontal front plane of the visor as worn."
- 2.12.            "luminous transmittance  $\tau_v$ " is defined in annex 13"
- 2.13.            "relative visual attenuation quotient" means the relative visual quotient (Q) and is defined in annex 13."

Paragraphs 2.10. to 2.16. (former), renumber as paragraphs 2.14. to 2.20.

Paragraph 2.17. (former), renumber as paragraph 2.21., and amend to read:

"2.21.            "routine testing" means ..... "

Paragraph 3.1.1.3.1., amend to read:

"..... and of its means of attachment to the helmet. The drawings ....."

Paragraph 3.1.1.5., amend to read:

"3.1.1.5.        For each visor type, if any, 7 (+3 if optional test for mist retardant visor is carried out) visors taken from a sample of not less than 14 (+ 6 if optional test) specimens. 6 (+ 3 if optional test) visors shall be subjected to the tests and the seventh (or tenth if optional test) shall be retained by the technical service responsible for conducting the approval test."

Paragraph 3.2.1., amend to read:

"..... be accompanied by the following:"

Paragraph 3.2.1.2., amend to read:

"3.2.1.2.        A technical description of the visor stating materials used, ....."

Paragraph 3.2.1.4., amend to read:

"3.2.1.4. For each visor type, if any, 7 (+3 if optional test for mist retardant visor is carried out) visors taken from a sample of not less than 14 (+ 6 if optional test) specimens and the helmets to which the visors are intended to be fitted. 6 (+ 3 if optional test) visors shall be subjected to the tests and the seventh (or tenth if optional test) shall be retained by the technical service responsible for conducting the approval test."

Paragraph 3.3., amend to read:

"3.3. The competent authority shall verify the existence of satisfactory arrangements in order to ensure effective control of the conformity of production in accordance with the provisions of paragraph 10. and annex 12 before type approval is granted."

Paragraph 4.1.1., amend to read:

".... an indication of the size and, if appropriate, an indication of the unsuitability of the lower face cover to offer any protection against impacts to the chin."

Paragraph 4.1.2., amend to read:

"4.1.2. On the visor, the applicant's trade name or mark and, if appropriate, an indication of the unsuitability of the visor for use during the hours of darkness or in conditions of poor visibility."

Paragraph 4.2., amend to read:

"..... trade name or mark and, if appropriate, an indication of the unsuitability of the visor for use during the hours of darkness or in conditions of poor visibility."

Paragraph 5.1.2., amend to read: \*/

"5.1.2. An approval number shall be assigned to each type approved. Its first two digits (at present 05) shall indicate ...."

---

\*/ An amendment to this provision was omitted in the 04 series of amendments.

Paragraph 5.1.4., replace reference to paragraph 5.1.7. by reference to paragraph 5.1.9.

Paragraph 5.1.4.1.1., footnote 3/, amend to read:

"3/ 1 for ..., 8 for the Czech Republic, .... 24 for Ireland, ... 29 for Estonia, 30 (vacant), 31 for Bosnia and Herzegovina, 32 for Latvia; 33-36 (vacant), 37 for Turkey, 38-39 (vacant), 40 for The former Yugoslav Republic of Macedonia, 41 (vacant), 42 for the European Community (Approvals are granted by its Member States using their respective ECE symbol), and 43 for Japan. Subsequent numbers ... to the Agreement concerning the Adoption of Uniform Technical Prescriptions for Wheeled Vehicles, Equipment and Parts which can be fitted and/or be used on Wheeled Vehicles and the Conditions for Reciprocal Recognition of Approvals Granted on the Basis of These Prescriptions, and the numbers thus assigned ...."

Paragraph 5.1.4.1.2., amend to read:

"5.1.4.1.2. The approval number followed by:"

Insert a new paragraph 5.1.4.1.2.1., to read:

"5.1.4.1.2.1. a dash and symbol:

- "J" if the helmet does not have a lower face cover
- "P" if the helmet has a protective lower face cover, or
- "NP" if the helmet has a non protective lower face cover"

Paragraph 5.1.4.1.3. (former), renumber as 5.1.4.1.2.2. and amend to read:

"5.1.4.1.2.2. a dash followed by a production serial ..... "

Insert new paragraphs 5.1.4.1.3. and 5.1.4.1.4., to read:

"5.1.4.1.3. The marking and/or symbol denoting the unsuitability of the lower face cover, if appropriate.

5.1.4.1.4. The marking on the helmet and, if appropriate, lower face cover shall be clearly legible, indelible and resistant to wear."

Insert a new paragraph 5.1.5.1.3., to read:

"5.1.5.1.3. The symbol denoting daytime use only, if appropriate."

Insert new paragraphs 5.1.6. and 5.1.7., to read:

"5.1.6. The marking on the visor, shall be clearly legible, indelible and resistant to wear.

5.1.7. The marking on the visor, shall not be placed within the main visibility area."

Paragraph 5.1.6. (former), renumber as paragraph 5.1.8. and amend to read:

"..... approval marks for protective helmets and visors."

Paragraph 5.1.7. (former), renumber as paragraph 5.1.9.

Paragraph 5.1.8. (former), renumber as paragraph 5.1.10. and replace reference to paragraph 5.1.7. by reference to paragraph 5.1.9.

Paragraph 5.1.9. (former), renumber as paragraph 5.1.11. and replace reference to paragraph 5.1.7. by reference to paragraph 5.1.9.

Paragraphs 5.1.10. and 5.1.11. (former), renumber as paragraphs 5.1.12. and 5.1.13.

Paragraph 5.2.4.1.1., replace the reference to paragraph 5.1.4.1. by reference to paragraph 5.1.4.1.1. and delete the word "and".

Insert a new paragraph 5.2.4.1.3., to read:

"5.2.4.1.3. The symbol denoting daytime use only, if appropriate."

Paragraph 5.2.5., amend to read:

"5.2.5. The approval mark shall be clearly legible, indelible and resistant to wear."

Paragraph 6.2., amend to read:

"..... a lower face cover. If fitted with a non protective lower face cover the outer surface of the cover shall be marked «Does not protect chin from impacts» and/or with the symbol shown in figure 1 below indicating the unsuitability of the lower face cover to offer any protection against impacts to the chin."

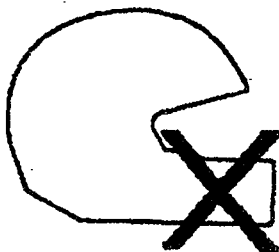

Figure 1: Symbol "Does not protect chin from impacts"



Paragraph 6.5., delete the sentences reading: "The outer surface shall . . . . integral lower face cover."

Paragraph 6.6., amend to read:

"6.6. All projections from or irregularities in the outer surface of the shell greater than 2 mm shall be tested for shear assessment according to paragraphs 7.4.1. or 7.4.2. The outer surface of the helmet shall be tested for friction assessment according to paragraphs 7.4.1. or 7.4.2."

Paragraph 6.7., amend to read:

"6.7. Any external projections other than press-fasteners shall be smooth and adequately faired. All external projections not more than 2 mm above the outer surface of the shell (e.g. rivet heads) shall have a radius of a minimum of 1 mm. All external projections more than 2 mm above the outer surface of the shell shall have a radius of a minimum of 2 mm."

Paragraph 6.11.8., delete the sentence reading: "When a helmet type . . . (such as thickest padding, etc.)."

Insert a new paragraph 6.15.3.4., to read:

"6.15.3.4. Visors shall have a luminous transmittance  $\tau_v \geq 80\%$ , relative to the standard illuminant D65. A luminous transmittance  $80\% > \tau_v \geq 50\%$ , measured by the method given in paragraph 7.8.3.2.1.1., is also permissible if the visor is marked with the symbol shown in figure 2 and / or with the English words "DAYTIME USE ONLY". The luminous transmittance shall be measured before the abrasion test.

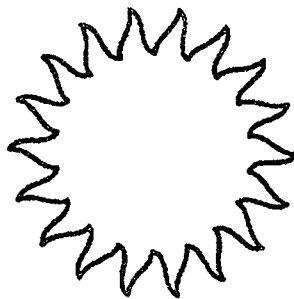

Figure 2: Symbol "Daytime use only"

Paragraph 6.15.3.4. (former), renumber as 6.15.3.5. and amend to read:

"..... field of vision. The light diffusion shall not exceed the limit in accordance with paragraph 7.8.3.2.1.2. when measured in accordance with one of the methods specified in annex 11.

If different assessments result in judging this, the requirements on scattered light and optical power shall be assessed over a measuring area 5 mm in diameter which includes the presumed error. In addition, the regular transmittance shall not deviate by more than  $\pm 5\%$  from the reference value, measured in one of two sight points specified in paragraph 6.15.3.8., at any point within the field of vision of the visor."

Paragraph 6.15.4., renumber as paragraph 6.15.3.6. and amend to read:

"..... visor shall be resistant to abrasion, resistant to impact and shall not give rise to any confusion between the colour used in road traffic sign and signals. The relative visual attenuation quotient (Q) shall not be less than:

0.80 for red and yellow signal lights;  
0.60 for green signal light;  
0.40 for blue signal light.

The relative attenuation quotient shall be measured by the method given in paragraph 7.8.3.2.1.1., before the abrasion test.

Note: When calculating the value of Q from the spectral measurements, the value in annex 14 shall be used. Linear interpolation of these values for steps smaller than 10 nm is permissible."

Insert new paragraphs 6.15.3.7. to 6.15.3.9., to read:

"6.15.3.7. In the range 500 nm to 650 nm, the spectral transmittance, measured by the method given in paragraph 7.8.3.2.1.1., of the visor shall not be less than 0.2  $\tau_v$ . The spectral transmittance shall be measured before the abrasion test.

6.15.3.8. The table contains the permissible refractive powers at the sight points. The sight points are located in the reference plane 32 mm to the right and the left of the longitudinal median plane (see fig. 2B).

Permissible refractive power values for visors

Spherical effect	Astigmatic effect	Prismatic effect difference		
		Horizontal		Vertical
$\frac{D_1 + D_2}{2}$	$ D_1 - D_2 $			
$m^{-1}$	$m^{-1}$	Base Out	Base In	
		cm/m	cm/m	cm/m
$\pm 0.12$	0.12	1.00	0.25	0.25

$D_1, D_2$ : Refractive effect in two main sectors

The requirements for the prismatic effect apply to the difference between the values at the two sight points.

The refractive powers shall be measured according to method specified in annex 15.

6.15.3.9. Mist Retardant Visor (Optional requirements)

The internal face of the visor is regarded as having a mist retardant facility if the square of the specular transmittance has not fallen below 80 per cent of the initial value without misting within 20 s when tested as described in annex 16. Such facility may be indicated by the English words "MIST RETARDANT".

Paragraph 7.1., amend to read (the table not modified):

"7.1. Each helmet .....

.....

The largest size of each helmet type shall be tested for impact absorption and rigidity. For tests of the retention system, helmet sizes shall be chosen such that the helmet to be tested shall be that offering the least favourable conditions (such as thickest padding, etc).

Additionally, for each smaller headform size within the size range ...."

Paragraph 7.3.1.2., amend to read:

"7.3.1.2. Marking of points and areas of impact

Before conditioning, the points and areas of impact are marked as indicated in paragraph 7.3.4.2. and annex 4 (fig. 3) and the helmet is positioned in accordance to annex 5."

Paragraph 7.3.1.3.1., amend to read (footnote 4/ not modified):

"7.3.1.3.1. The helmet shall be positioned in accordance with the requirements of annex 5 on a head form of appropriate size selected from among those listed in paragraph 7.3.3.2. 4/ When testing impact points B, X, P and R the helmet is tipped towards the rear so that the front edge of the helmet in the median plane is displaced by 25 mm; the retention system is then adjusted under the chin of the head form; if the system includes an adjustable chin strap, the strap is tightened as for normal use."

Insert a new paragraph 7.3.1.3.1.1., to read:

"7.3.1.3.1.1. When testing impact point S on a helmet with a protective lower face cover, the helmeted head form is tipped forwards so that the central vertical axis of the head form is inclined at an angle of  $65 \pm 3^\circ$  to the vertical and the vertical longitudinal plane of the helmeted head form has to be in a vertical position. If the impact point is to be between 15 mm of the rim, the helmeted headform shall be re-positioned so that the impact point is to be more than 15 mm from the rim"

Paragraph 7.3.1.3.2., amend to read:

" .... shall be horizontal. This prescription does not apply for the S impact point."

Paragraph 7.3.1.4., amend to read:

"7.3.1.4. Test

The test shall be completed not more than five minutes after the helmet is taken from the conditioning chamber. Tests at point S shall be carried out after tests at points B, X, P and R. The drop height shall be .... equal to:

7.5 (+ 0.15, - 0.0) m/s for both anvils specified in paragraphs 7.3.2.3.1. and 7.3.2.3.2.

5.5 (+ 0.15, - 0.0) m/s for tests at point S."

Paragraph 7.3.4.1., amend to read:

"7.3.4.1. Each test shall be carried out with 4 impacts on one helmet on the points B, X, P and R, in this sequence. When a helmet with a protective lower face cover is being tested then an additional point S shall be impacted after the four other points, but only against the anvil specified in paragraph 7.3.2.3.1."

(In addition, correct the French version to read:

".... dans cet ordre. Les casques équipés du protection intégral du bas de visage sont en outre soumis à un impact ....")

Paragraph 7.3.4.1.1., amend to read:

"7.3.4.1.1. After each impact the helmet shall be re-positioned correctly on the head form prior to the next impact, without interfering with the adjustment of the retention system. Before each impact on the point S the helmet shall be re-positioned correctly on the head form and the retention system adjusted under the chin of the head form; if the system includes an adjustable chin strap, the strap is tightened as much as possible."

Paragraph 7.3.4.1.2., should be deleted.

Paragraph 7.3.4.2., amend to read:

"7.3.4.2. The points of impact are defined for each helmet:

B, in the frontal area, situated .... the AA' plane.

X, in either the left or right .... the AA' plane.

R, in the rear area, situated .... the AA' plane.

P, in the area with a radius of 50 mm, which centre is the intersection of the central vertical axis and the outer shell of the helmets.

S, in the lower face cover face area, situated within an area bounded by a sector of 20° divided symmetrically by the vertical longitudinal plane of symmetry of the helmet.

Impacts at points B, X and R should be within 10 mm radius of the defined point."

Paragraph 7.3.5., amend to read:

"7.3.5.           Combination of conditioning and anvils

Conditioning: Solvent plus ...	Anvils <u>1/</u>
Ambient	Flat and kerbstone
Heat	Kerbstone <u>2/</u>
Low temperature <u>3/</u>	Flat <u>2/</u>
Ultraviolet radiation and moisture	Flat or kerbstone (to be selected by the laboratory)

- 1/ Point S shall only be impacted against the flat anvil.  
2/ Only for the largest helmet size. For smaller head forms in the size range of the helmet type either anvil may be used.  
 See paragraph 7.1.  
3/ Only each helmet size subjected to low-temperature conditioning shall undergo the impact test at point S."

Paragraph 7.4., (currently "not used"), amend to read:

"7.4                Test for projections and surface friction

7.4.1.            Test for projections and surface friction (method A)

7.4.1.1.         Description of test

7.4.1.1.1.      Principle

The rotation-inducing forces caused by projections on the helmet and friction against the outer surface of the helmet which occur when a helmeted headform is dropped vertically on to an inclined anvil are measured in the longitudinal axis of the anvil. The peak force and its integral with respect to time over the duration of the positive impulse are used as performance criteria.

7.4.1.1.2.      Selection and positioning of the helmet

7.4.1.1.2.1.    An appropriate size helmet shall be selected to fit the headform referred to in paragraph 7.4.1.2.6. The horizontal axis of the helmet shall be determined by placing the helmet on a headform, of a type referred to in paragraph 7.3.3., according to the requirements of annex 5. The helmet shall then be removed from that headform and placed on a headform of a type referred to in paragraph 7.4.1.2.6. A load of 50 N is applied to the crown of the helmet in order to adjust the helmet on the headform such that there is contact between the crown of the headform and the inner surface of the helmet. The horizontal plane of the helmet shall then be adjusted to be within  $90^\circ \pm 5^\circ$  of the vertical

axis of the headform. The retention system is then adjusted under the chin of the headform; if the system includes an adjustable chin strap, the strap is tightened as much as possible.

7.4.1.1.2.2. The test headform shall be so positioned that the chosen impact point on the helmet is vertically above the upper part of the face of the anvil.

7.4.1.1.2.3. The helmet shall be tested in any condition in which it may be placed on the market, that is both with and without accessories if they are supplied as original equipment. Helmets placed on the market with a visor shall be tested with the visor in the closed position.

7.4.1.1.3. Test

The drop height shall be such that the unit constituted by the headform and helmet falls on the test anvil at a velocity which, immediately before impact, is equal to 8.5 (-0.0/+0.15) m/s.

7.4.1.2. Apparatus (see annex 8, fig. 1b)

7.4.1.2.1. Description

The test apparatus shall comprise:

An anvil rigidly fixed to a base;

A free fall guidance system;

A mobile system supporting the helmeted headform;

A headform conforming to that referred to in paragraph 7.4.1.2.6., and

A system which may be adjusted such that the point of impact can be brought into correspondence with the upper part of the face of the anvil.

A means of recording the continuously changing transmitted anvil force during the impact.

A suitable energy-absorbing base and catch net to prevent damage to the helmet after the impact.

7.4.1.2.2. Base

This shall conform to the requirements specified in paragraph 7.3.2.2.

7.4.1.2.3. Anvil

- 7.4.1.2.3.1 The anvil is mounted securely at an angle of 15° to the vertical with provision for fore-and-aft adjustment. The anvil has a minimum width of 200 mm and is adaptable to carry either of two different impact surfaces as follows:
- 7.4.1.2.3.1.1. The bar anvil consists of a series of at least 5 horizontal bars at 40 mm centres. Each bar is made from a steel strip of height 6 mm and width 25 mm with its uppermost edge machined to a 1 mm radius and the lower 15 mm of its face chamfered at an angle of 15° so that, as mounted, the upper edge of each bar is fully exposed from vertically above. The bars are case-hardened to a depth of approximately 0.5 mm.
- The bar anvil should be used to assess the tangential forces and their integrals with time caused by projections on the helmet, e.g. visor fittings, screws, press studs and steps in the shell surface, etc.
- 7.4.1.2.3.1.2. The abrasive anvil is a sheet of grade 80 closed-coat aluminium oxide abrasive paper with a minimum supported length of 225 mm and is securely clamped to the base of the anvil to prevent slippage.
- The abrasive anvil should be used to assess the tangential forces and their integrals with time caused by friction against the outer surface of the helmet. This is particularly applicable to selected areas of helmets, the outer surface of which either have significant variations of curvature or are made of more than one material.
- 7.4.1.2.3.2. The anvil is fitted with force transducer(s) connected to recording apparatus so that the transmitted longitudinal force component can be measured and continuously recorded with an accuracy of  $\pm 5$  per cent during a glancing blow to any part of its exposed surface.
- 7.4.1.2.4. Mobile system and guides
- The mobile system supporting the headform shall be such that its characteristics do not affect the measurement of force in the anvil. It shall also be such that any point in the area above the line ACDEF can be positioned vertically above the anvil. The guides shall be such that the impact velocity is not less than 95 per cent of the theoretical velocity.
- 7.4.1.2.5. Force and measuring assembly
- The force transducers fitted to the anvil shall be capable of withstanding a maximum force of 20 000 N without damage. The measuring system including the anvil assembly shall have a frequency response in accordance with channel frequency class (CFC) 1 000 of the International Standard ISO "Road



vehicles - Techniques of measurement in impact tests -  
Instrumentation" (Ref. No. ISO 6487:1980).

7.4.1.2.6. Headform

The headform shall be that referred to in paragraph 7.3.3.  
characterised by the symbol J.

7.4.1.3. Selection of impact points

Any point above the line ACDEF on the helmet shell may be  
selected. The impact point should be selected with regard  
to the anvil against which the helmet is to be tested,  
taking into account the function of the anvils given in  
paragraphs 7.4.1.2.3.1.1. and 7.4.1.2.3.1.2. The helmet  
shall be tested as many times as necessary to ensure that  
all notable features are evaluated.

When the bar anvil is used, evaluate all different external  
projections greater than 2 mm above the outer surface of the  
shell. Re-orientate the helmet as necessary to allow any  
specific projection to be impacted from the direction that  
is likely to produce the greatest force and/or the greatest  
impulse where impulse is the integral of force with respect  
to time over the duration of the impact.

Note: The primary impact site on any projection is likely to  
be opposite to the site where the projection receives  
maximum support. For example, the primary impact site on a  
visor cover plate assembly is opposite to the area where the  
visor and cover plate locates in a recess in the shell.

When the abrasive anvil is used, evaluate the front, rear  
sides and crown areas of the helmet, selecting within the  
general areas, sites on the outer surface which are likely  
to produce the greatest force and/or the greatest impulse  
where impulse is the integral of force with respect to time  
over the duration of the impact. Examples of such areas are  
those having least curvature or areas having more than one  
type of surface finish, for example a painted shell  
partially overlaid by a fabric cover.

The rim of the shell and the upper and lower edge of the  
visor situated within an area bounded by a sector of 120°  
divided symmetrically by the vertical longitudinal plane of  
symmetry of the helmet do not constitute a projection for  
the purpose of this test.

7.4.1.4. Requirements

7.4.1.4.1. When tested against the bar anvil the helmet shall satisfy  
the following requirements:

- 7.4.1.4.1.1. the peak longitudinal force measured on the anvil shall not exceed 2 500 N, nor shall its integral with respect to time over the duration of the impact exceed 12.5 Ns for any of the selected impact points.
- 7.4.1.4.2. When tested against the abrasive anvil, a second helmet shall satisfy the following requirements:
  - 7.4.1.4.2.1. the peak longitudinal force measured on the anvil shall not exceed 3 500 N, nor shall its integral with respect to time over the duration of the impact exceed 25 Ns for any of the selected impact points."
- 7.4.2. Test for projections and surface friction (method B)
  - 7.4.2.1. Description of test
    - 7.4.2.1.1. Principle

The rotation-inducing forces caused by projections on the helmets and friction against the outer surface of the helmets are assessed firstly by a shear impact on the projections using a shear edge against which the projections shall shear away, be detached, or permit the shear edge to slide past the projections. The friction is assessed by the displacement of a carriage abrading the outer surface of the helmet. The shear impact and abrading carriage displacement are generated by a drop weight device.
    - 7.4.2.1.2. Positioning of the helmets
      - 7.4.2.1.2.1. The helmet is placed on a headform of appropriate size in accordance with the requirements of annex 5. The helmet is tipped towards the rear so that the front edge of the helmet in the median plane is displaced by 25 mm; if the helmet includes an adjustable chin strap, the strap shall be tightened as much as possible. The headform shall be so positioned that the chosen location on the helmet can be positioned in contact with the upper surface of the horizontal carriage.
      - 7.4.2.1.2.2. The helmet shall be tested in any condition in which it may be placed on the market, that is both with and without accessories if they are supplied as original equipment. Helmets placed on the market with a visor shall be tested with the visor in the closed position.

## 7.4.2.1.3. Test

## 7.4.2.1.3.1. Test of projection

The headform is adjusted in order to have the chosen projection on the carriage so that the shear edge is positioned 50 mm from the projection and makes lateral contact with the projection after the drop weight is released from its upper position.

## 7.4.2.1.3.2. Test of outer surface

The abrasive paper is mounted on the carriage in the position specified in paragraph 7.4.2.2.2. The chosen outer surface of the helmet is lowered on to the abrading carriage at the centre of the flat surface without abrasive paper. A loading mass is applied in accordance with paragraph 7.4.2.2.8. The drop weight is released from its upper position in accordance with paragraph 7.4.2.2.5. The abrasive paper shall be changed after every test.

## 7.4.2.2. Apparatus (a suitable apparatus is illustrated in annex 8, figure 1c)

## 7.4.2.2.1. Description

The test apparatus shall comprise:

A horizontal guided carriage with interchangeable attachments for abrasive paper or a shear edge

A horizontal guide and support for this carriage

A roller with a wire rope or a strap or a similar flexible connection

A lever connecting the headform to the test apparatus with a hinge

An adjustable system supporting the headform

A drop weight to load the lower end support of the wire rope, or a strap, after the weight is released

A system to support a headform and to apply a force to the helmet normal to the carriage

## 7.4.2.2.2. Carriage

For friction assessment the carriage bears a sheet of grade 80 closed-coat aluminium oxide abrasive paper with a supported length of 300 (- 0.0/+ 3.0) mm and securely clamped to the carriage to prevent slippage. At its end towards the drop weight

and in this direction the carriage has a 80 mm  $\pm$  1 mm long smooth steel area not being covered by the abrasive paper and higher than the rest of the carriage by the thickness of the abrasive paper plus 0.5  $\pm$  0.1 mm.

For shear assessment the carriage is provided in the middle, with a bar made from a steel strip of height 6 mm and width 25 mm with its uppermost edges machined to a 1 mm radius. The bar is case-hardened to a depth of approximately 0.5 mm.

The carriage and either attachment shall have a total mass of 5 (- 0.2/+ 0.0) kg.

7.4.2.2.3. Horizontal guide

The horizontal guide which guides and supports the carriage may consist of two cylindrical bars on which the ball bearings of the carriage may freely travel.

7.4.2.2.4. Roller with a wire rope or strap

The rollers shall have a diameter of at least 60 mm and lead the wire rope or strap from the horizontal into the vertical direction. The horizontal end of the wire rope or strap is fixed to the carriage, the vertical end is fixed to the drop weight.

7.4.2.2.5. Drop weight

The drop weight shall have has a mass of 15 (- 0.0/+ 0.5) kg. For shear assessment the free drop height shall be 500 (- 0.0/ + 5.0) mm with provision for further possible travel of at least 400 mm. For testing the friction assessment the free drop height shall be 500 (- 0.0/+ 5.0) mm with provision for further possible travel of at least 400 mm.

7.4.2.2.6. Headform support

The system supporting the headform shall be such that any point above the line ACDEF can be positioned in contact with the upper surface of the carriage.

7.4.2.2.7. Lever and hinge

A rigid lever shall connect the headform support to the test apparatus with a hinge. The height of the hinge pivot above of the upper surface of the carriage shall not be greater than 150 mm.

7.4.2.2.8. Loading mass

A loading system is used to generate a force of 400 (- 0.0/+ 10.0) N on the helmet normal to the surface of the carriage. This force shall be measured before each test.

7.4.2.2.9. Verification of the test apparatus

With the unloaded carriage and a drop height of 400 mm the velocity of the carriage after 250 mm of travel shall be  $5 \pm 0.1$  m/sec. This requirement shall be verified after every 500 helmet tests or ones every 3 months whichever is the sooner.

7.4.2.3. Selection of test points

Any point above the line ACDEF on the helmet may be selected for friction and/or shear assessment. A helmet shall be tested as many times as necessary to ensure that all notable features are evaluated with one test only per feature. Re-orientate the helmet as necessary to allow every feature to be tested. For shear assessment evaluate all different external projections greater than 2 mm above the outer surface of the shell. For friction assessment evaluate areas of the outer surface that are likely to produce the greatest friction.

The rim of the shell and the upper and lower edge of the visor situated within an area bounded by a sector of  $120^\circ$  divided symmetrically by the vertical longitudinal plane of symmetry of the helmet do not constitute a projection for the purpose of this test.

7.4.2.4. Requirements

7.4.2.4.1. For shear assessment the tested projection shall shear away, be detached or alternatively shall not prevent the assessment bar from sliding past the projection. In all cases the bar on the horizontal carriage shall travel past the projection.

7.4.2.4.2. For friction assessment the abrasive carriage shall not be brought to rest by the helmet."

Paragraph 7.5.1., amend to read (figure not modified):

"7.5.1. The helmet, after undergoing ambient-temperature and hygrometry conditioning, shall be placed between two parallel plates by means of which a known load can be applied along the longitudinal axis  $\ast/$  (line LL in the figure) or the transverse axis (line TT in the figure). Plates surface shall be large enough to contain at least a circle of diameter 65 mm. An initial load of 30 N shall be applied, at a minimum plates speed of 20 mm/min, and after two minutes the distance between the two plates shall be measured. The load shall then be

increase by 100 N, at a minimum plates speed of 20 mm/min, and then wait for two minutes. This procedure shall be repeated until the application of a load of 630 N.

\*/ Note: During the test along the longitudinal axis, the contact point between the helmet and one of the two plates must be the "B" impact point."

Paragraph 7.5.2., amend to read:

"7.5.2. The load applied to the plates shall be reduced to 30 N, at a minimum plates speed of 20 mm/min; the distance between the plates shall then be measured."

Paragraph 7.8.1., amend to read:

"7.8.1. Sampling and use of samples

The 7 (+3 if optional test) visors are used as follows:

Paragraph	Test	1	2	3	4	5	6	7	7	8	9	10	Tot		
									If optional test						
6.15.3.	Field of vision of the visor	X						R E T A I N E D				R E T A I N E D	1		
6.15.3.4.	Luminous transmittance	X	X	X											3
6.15.3.5.	Light diffusion														
6.15.3.6.	Recognition of signal lights														
6.15.3.7.	Spectral transmittance														
6.15.3.8.	Refractive powers				X	X	X								3
6.15.3.9.	Mist retardant visor (optional)									X	X		X		3
7.8.2.	Mechanical characteristics				X	X	X						3		
7.8.3.	Optical quality and scratch resistance	X	X	X									3		

Note: The test for recognition of signal lights may be dispensed with in the case of visors with luminous transmittance  $\tau_v \geq 80\%$

Insert a new paragraph 7.8.1.1., to read:

"7.8.1.1. Prior to any type of further conditioning for mechanical or optical test, as specified in paragraph 7.8.1., each visor shall be subject to the ultraviolet conditioning in accordance with the provision of paragraph 7.2.5.1.

Paragraph 7.8.3.2.1.1., amend to read:

"7.8.3.2.1.1. In a parallel beam, with the test specimens being irradiated vertically, determine the spectral transmittance values between 380 nm and 780 nm and then the transmittance and the visual attenuation quotient in accordance with the equations given in annex 13.  
To calculate the luminous transmittance shall be used the spectral distribution of standard illuminant D65 and the spectral values of the colorimetric 2° standard observer CIE 1931 according to ISO/CIE 10256. The product of the spectral distribution of standard illuminant D65 and the spectral values of the colorimetric 2° standard observer CIE 1931 according to ISO/CIE 10256 is given in annex 14. Linear interpolation of these values for steps smaller than 10 nm is permissible."

Paragraph 7.8.3.2.1.2., amend to read:

"7.8.3.2.1.2. The light diffusion shall not exceed the following values for each method:

Before abrasion		After abrasion	
0.65 cd/m <sup>2</sup> /l	a/ c/	5.0 cd/m <sup>2</sup> /l	a/ c/
2.5%	b/	20%	b/

a/ measured according to annex 11, method (a);  
b/ measured according to annex 11, method (b);  
c/ measured according to annex 11, method (c)."

Insert new paragraphs 9. to 9.3.4., to read:

"9. PRODUCTION QUALIFICATION

9.1. In order to make sure that the manufacturer's production system is satisfactory, the technical service which conducted the approval tests must carry out tests to qualify production in accordance with paragraphs 9.2. and 9.3.

9.2. Qualifying the production of helmets

The production of each new approved type of helmet must be subjected to production qualification tests.

For this purpose, a random sample from the first batch will be taken of 40 helmets of the largest size (50 helmets if the test on the S point is involved) and 10 helmets of the smallest size.

The first batch is considered to be the production of the first tranche containing a minimum of 200 helmets and a maximum of 3 200 helmets.

9.2.1. Test on the system of retention

9.2.1.1. The 10 helmets of the smallest size are subjected to test of the retention system described in paragraph 7.6.2.

9.2.2. Shock absorption test

9.2.2.1. From the 40 helmets (50 if the S point test is involved) take 4 (5 if the S point test is involved) groups each with 10 helmets.

9.2.2.2. All of the helmets in a group must first be subjected to the same conditioning treatment and then subjected to the shock absorption test described in paragraph 7.3. at the same point of impact. The first group of 10 helmets will be subjected to the shock absorption test at point B, the second at point X, the third at point P, the fourth at point R (and the fifth at point S if it is involved). The conditioning and the anvil for each group are chosen by the technical department which conducted the approval tests.

9.2.2.3. The results of the tests described in paragraphs 9.2.1. and 9.2.2. must comply with the following two conditions:

no value shall exceed 1.1 L, and

$\bar{X} + 2.4 S$  shall not exceed L

where:

L = the limit value prescribed for each approval test

$\bar{X}$  = the mean of the values

S = the standard deviation of the values

The value of 2.4 specified above is only valid for a series of tests applied to at least 10 helmets, tested under the same conditions.



- 9.2.2.3.1. No Contracting Party applying this Regulation shall apply the criterion

$X + 2.4 S$  shall not exceed  $L$

as contained in paragraph 9.2.2.3., to the HIC value as measured in accordance with paragraph 7.3.

- 9.3. Production qualification of the visors

The production of each new approved type of visors (approved as such or as forming part of the helmet) must be subjected to production qualification tests.

For this purpose, a random sample from the first batch will be taken of 20 visors (30 visors if mist-retardant are involved).

The first batch is considered to be the production of the first tranche containing a minimum of 200 visors and a maximum of 3200 visors.

- 9.3.1. Test group A

light transmission — paragraph 6.15.3.4.  
recognition of light signals — paragraph 6.15.3.6.  
spectral transmission — paragraph 6.15.3.7.  
light diffusion — paragraph 6.15.3.5.  
optical qualities and resistance to scratches —  
paragraph 7.8.3.

Test group B

refractivity — paragraph 6.15.3.8.  
mechanical characteristics — paragraph 7.8.2.

Test group C (optional)

mist-retardant — paragraph 6.15.3.9.

- 9.3.2. From the 20 visors (30 if mist-retardant is involved) take two (or three if mist-retardant is involved) groups each of 10 visors.
- 9.3.3. The first group of 10 visors will be subjected to each of the test in-group A, the second group to each of the test in-group B (and the third group the test in-group C if mist-retardant is involved).
- 9.3.4. The results of the tests described in paragraph 9.3.3. must comply with the values prescribed for each approval test."

Paragraphs 9. to 9.5.6. (former), should be deleted.

Insert new paragraphs 10. to 10.6.2.5., to read:

- "10. CONFORMITY OF PRODUCTION
- 10.1. The approved helmet or visor (as such or forming part of the helmet) satisfying the acceptability conditions of production qualification and in application of the present regulation must be manufactured in such a way as to conform to the type approved by complying with the stipulations of paragraphs 6. and 7.
- 10.2. In order to verify that the conditions stated in section 10.1 have been met, appropriate control of the production must be performed.
- 10.3. The holder of the approval is responsible for the conformity of production procedures and he must in particular:
- 10.3.1. Ensure the existence of effective procedures so that the quality of the products can be inspected;
- 10.3.2. Have access to the testing equipment needed to inspect the conformity of each approved type;
- 10.3.3. Ensure that the test results are recorded and that the annexed documents remain available for a time period of 10 years after test;
- 10.3.4. Analyse results of each type of test in order to verify and ensure the stability of the helmet or visors characteristics, making allowance for variations of an industrial production;
- 10.3.5. Ensure that for each type of helmet or visors at least those tests prescribed in paragraphs 10.5. and 10.6. of the present Regulation are carried out;
- 10.3.6. Ensure that any set of samples or test pieces giving evidence of non-conformity to the standard test concerned gives rise to a further sampling and test. All the necessary steps must be taken to restore conformity of the corresponding production.
- 10.4. The authority which has granted the approval may at any time verify the conformity control methods applied in each production facility.
- 10.4.1. At every inspection, the test records and production progress records must be available to the visiting inspector.
- 10.4.2. The inspector may select samples at random to be tested in the manufacturer's test laboratory (in the case where the

manufacturer has such a laboratory). The minimum number of samples may be determined according to the results of the manufacturer's own verification.

- 10.4.3. When the level of control appears unsatisfactory, or when it seems necessary to check the validity of the tests carried out in application of paragraph 10.4.2., the inspector must select samples which will be sent to the technical service which conducted the approval tests.
- 10.4.4. The relevant authorities may carry out all of the tests prescribed in the present Regulation.
- 10.4.5. The relevant authorities must conduct inspections in accordance to annex 12. In cases where unsatisfactory results are found during an inspection, the approval authority must ensure that all necessary steps are taken to restore conformity of production as rapidly as possible.
- 10.5. Minimum conditions for the control of conformity of helmets. In accordance with the relevant authorities, the holder of an approval will do the control of conformity following the method of batch control (paragraph 10.5.1.) or following the method of continuous control (paragraph 10.5.2.).
- 10.5.1. Batch control
- 10.5.1.1. The holder of an approval must divide the helmets into batches which are as uniform as possible in regard to raw materials or intermediate products involved in their manufacture, and in regard to production conditions. The numbers in a batch must not exceed 3200 units.  
In accordance with the relevant authorities the tests can be carried out by the technical service or by the holder of an approval.
- 10.5.1.2. A sample must be taken in each batch in accordance with the provisions of paragraph 10.5.1.4. from a minimum of 20% of the batch quantity, which has to be produced of the actual batch.
- 10.5.1.3. The size of the helmets and the tests to be conducted are given in paragraph 10.5.1.4.

10.5.1.4. In order to be accepted, a batch of helmets must satisfy the following conditions:

Numbers in the batch	Number of samples/helmet size	Combined number of samples	TESTS TO BE CONDUCTED		Acceptance criteria	Rejection criteria	Degree of control rig
			Shock absorption (para. 7.3.)	Detaching test (para. 7.7.) Retention system (para. 7.6.)			
$0 < N \leq 500$	1 <sup>st</sup> = 1LS+1SS+2MS 2 <sup>nd</sup> = 1LS+1SS+2MS	8	1 LS + 2 MS 1 LS + 2 MS	1 on SS* 1 on SS*	0 1	2 2	Normal
$500 < N \leq 3200$	1 <sup>st</sup> = 2LS+1SS+2MS 2 <sup>nd</sup> = 2LS+1SS+2MS	10	2 LS + 2 MS 2 LS + 2 MS	1 on SS* 1 on SS*	0 1	2 2	Normal
$0 < N \leq 1200$	1 <sup>st</sup> = 3LS+2SS+3MS 2 <sup>nd</sup> = 3LS+2SS+3MS	16	3 LS + 3 MS 3 LS + 3 MS	2 on SS* 2 on SS*	0 1	2 2	Strengthened
$1200 < N \leq 3200$	1 <sup>st</sup> = 5LS+3SS+5MS 2 <sup>nd</sup> = 5LS+3SS+5MS	26	5 LS + 5 MS 5 LS + 5 MS	3 on SS* 3 on SS*	0 3	3 4	Strengthened

**Note:** LS signifies = largest size (max. 62)  
MS signifies = medium size  
SS signifies = smallest size (min. 50)  
\* = Both tests (para. 7.7. before para. 7.6.) are carried out on the same helmet.  
The absorption of the shocks is arranged on B,X, P, R, S for the same helmet

The conditioning and the anvil in the case of the shock absorption tests are chosen by the technical service which carried out the approval tests.

This dual sampling plan functions as follows:

For a normal control, if the first sample does not contain any defective units the batch is accepted without testing a second sample. If it contains two defective units the batch is rejected.

Finally, if it contains one defective unit a second sample is extracted and it is the cumulative number which must satisfy the condition of column 7 of the table above.

There is a change from normal control to strengthened control if, out of 5 consecutive batches, two are rejected. Normal control is resumed if 5 consecutive batches are accepted.

If 2 consecutive batches subjected to the strengthened control are rejected, the provisions of paragraph 11. are applied.

10.5.1.5. The remainder of the tests, not specified in the table above but which have to be conducted in order to obtain approval, must be conducted at least once per year.

- 10.5.1.6. The control of helmet conformity is undertaken starting with the batch manufactured after the first batch which was subjected to production qualification.
- 10.5.1.7. The test results described in paragraph 10.5.1.4. must not exceed 1.1L, where L is the limit value prescribed for each approval test.
- 10.5.2. (Continuous control
- 10.5.2.1. The holder of an approval shall be obliged to carry continuous quality control on a statistical basis and by sampling. In accordance with the relevant authorities, the tests can be carried out by the technical service or by the holder of an approval.
- 10.5.2.2. The samples must be taken in accordance with the provisions of paragraph 10.5.2.4.
- 10.5.2.3. The helmets size is taken at random and the tests to carry out are described in paragraph 10.5.2.4.
- 10.5.2.4. For the production to be considered conform, the tests of continuous control shall meet the following requirements.

<u>TESTS TO BE CONDUCTED</u>				
Helmets Taken	Shock absorption kerbstone anvil, heat (para. 7.3.)	Shock absorption flat anvil, low temperature (para. 7.3.)	Detaching (para. 7.7.) Retention system (para. 7.6.)	Degree of control rigour
0.8% means one helmet taken from every 125 manufactured	Helmet No.1	Helmet No.2	Helmet No.3*	Normal
1.5% means one helmet taken from every 66 manufactured	Helmet No.1	Helmet No.2	Helmet No.3*	Strengthened
<p><u>Note:</u> * = Both tests (para. 7.7. before para. 7.6.) are carried out on the same helmet. The absorption of the shocks is arranged on B, X, P, R, S for the same helmet.</p>				

This dual sampling plan functions as follows:

If the helmet tested is considered conform, the production is conform

If the helmet does not meet the requirements, a second helmet shall be taken,

If the second helmet tested is considered conform, the production is conform,

If both helmets do not meet the requirements, the production is not conform, helmets which are likely to present the same failure are withdrawn.

There is a change from normal control to strengthened control if, out of 22 helmets tested consecutively, the production is taken twice.

Normal control is resumed if 40 helmets taken consecutively are conforming.

If two consecutive production subjected to the strengthened control are rejected, the provisions of paragraph 11. are applied.

- 10.5.2.5. The remainder of the tests, not provisioned in the table above but which have to be conducted in order to obtain approval, must be conducted at least once per year.
- 10.5.2.6. The continuous control of helmets is undertaken starting after the production qualification.
- 10.5.2.7. The test results described in paragraph 10.5.2.4. must not exceed 1.1L, where L is the limit value prescribed for each approval test.
- 10.6. Minimum conditions for the control of conformity of visors
- In accordance with the relevant authorities, the holder of an approval will do the control of conformity following the method of batch control (paragraph 10.6.1.) or following the method of continuous control (paragraph 10.6.2.).
- 10.6.1. Batch control
- 10.6.1.1. The holder of an approval must divide the helmets into batches which are as uniform as possible in regard to raw materials or intermediate products involved in their manufacture, and in regard to production conditions. The numbers in a batch must not exceed 3200 units. In accordance with the relevant authorities the tests can be carried out by the technical service or by the holder of an approval.
- 10.6.1.2. A sample must be taken in each batch in accordance with the provisions of paragraph 10.6.1.3. from a minimum of 20% of the batch quantity, which has to be produced of the actual batch.

10.6.1.3. In order to be accepted, a batch of visors must satisfy the following conditions:

			TESTS TO BE CONDUCTED					
Numbers in the batch	Number of samples	Combined number of samples	Group A	Group B	Group C*	Acceptance criteria	Rejection criteria	Stringency of inspection
$0 < N \leq 500$	1 <sup>st</sup> = 4 (5*) 2 <sup>nd</sup> = 4 (5*)	8	3 3	1 1	1 1	0 1	2 2	Normal
$500 < N \leq 3200$	1 <sup>st</sup> = 5 (6*) 2 <sup>nd</sup> = 5 (6*)	10	4 4	1 1	1 1	0 1	2 2	Normal
$0 < N \leq 1200$	1 <sup>st</sup> = 8 (10*) 2 <sup>nd</sup> = 8 (10*)	16	6 6	2 2	2 2	0 1	2 2	Strengthened
$1200 < N \leq 3200$	1 <sup>st</sup> = 13 (16*) 2 <sup>nd</sup> = 13 (16*)	26	10 10	3 3	3 3	0 3	3 4	Strengthened

\* Additional visor (s) in the case where the visor (s) have been tested in accordance with mist retardant for approval

Test group A

Light transmission — para. 6.15.3.4.

Recognition of light signals — para. 6.15.3.6.

Spectral transmission — para. 6.15.3.7.

Light diffusion — para. 6.15.3.5.

Optical qualities and resistance to scratches — para. 7.8.3.

Test group B

Refractivity — para. 6.15.3.8.

Mechanical characteristics — para. 7.8.2.

Test group C

Mist retardant - para. 6.15.3.9.

This dual sampling plan functions as follows:

For a normal control, if the first sample does not contain any defective units the batch is accepted without testing a second sample. If it contains two defective units the batch is rejected.

Finally, if it contains one defective unit a second sample is extracted and it is the cumulative number which must satisfy the condition of column 7 of the table above.

There is a change from normal control to strengthened control if, out of 5 consecutive batches, two are rejected. Normal

control is resumed if 5 consecutive batches are accepted.

If 2 consecutive batches subjected to the strengthened control are rejected, the provisions of paragraph 11. are applied.

- 10.6.1.4. The control of visor conformity is undertaken starting with the batch manufactured after the first batch which was subjected to production qualification.
- 10.6.1.5. The test results described in paragraph 10.6.3. must not exceed  $1.1L$ , where  $L$  is the limit value prescribed for each approval test.
- 10.6.2. Continuous control
- 10.6.2.1. The holder of an approval shall be obliged to carry continuous quality control on a statistical basis and by sampling. In accordance with the relevant authorities, the tests can be carried out by the technical service or by the holder of an approval.
- 10.6.2.2. The samples must be taken in accordance with the provisions of paragraph 10.6.2.3.
- 10.6.2.3. For the production to be considered conform, the tests of continuous control shall meet the following requirements

TESTS TO BE CONDUCTED				
Visors Taken	Group A	Group B	Group C	Stringency of inspection
0.8% means one visor every 125 manufactured	Visors No. 1, 2, 3	Visor No. 4	Visor No. 5*	Normal
1.5% means one visor taken every 66 manufactured	Visors No. 1, 2, 3	Visor No. 4	Visor No. 5*	Strengthened
<p>Note: Additional visor(s) in the case where the visor(s) have been tested in accordance with mist retardant for approval.</p>				

Test group A

Light transmission — para. 6.15.3.4.

Recognition of light signals — para.6.15.3.6.

Spectral transmission — para. 6.15.3.7.

Light diffusion — para. 6.15.3.5.

Optical qualities and resistance to scratches — para. 7.8.3.

Test group B

Refractivity — para. 6.15.3.8.



Mechanical characteristics — para. 7.8.2.

Test group C

Mist retardant - para. 6.15.3.9.

This dual sampling plan functions as follows:

If the visor tested is considered conform, the production is conform

If the visor does not meet the requirements, a second visor shall be taken,

If the second visor tested is considered conform, the production is conform,

If both visors do not meet the requirements, the production is not conform, visors which are likely to present the same failure are withdrawn.

There is a change from normal control to strengthened control if, out of 22 visors tested consecutively, the production is taken twice. Normal control is resumed if 40 visors taken consecutively are conforming.

If two consecutive production subjected to the strengthened control are rejected, the provisions of section 11 are applied.

10.6.2.4. The continuous control of visors is under taken starting after the production qualification.

10.6.2.5. The test results described in paragraph 10.6.2.3. must not exceed 1.1L, where L is the limit value prescribed for each approval test."

Paragraphs 10. to 13. (former), renumber as paragraphs 11. to 14.

Paragraph 13.1. (former), renumber as paragraph 14.1., and amend to read:

"14.1. Every protective helmet placed on the market shall bear a ... national language, or at least one of the national languages of the country of destination. This information shall contain:

For adequate protection ..... should be replaced

and, if fitted with a non protective lower face cover:

"does not protect chin from impacts" together with the symbol indicating the unsuitability of the lower face cover to offer any protection against impacts to the chin."

Paragraphs 13.2. to 13.5. (former), renumber as paragraphs 14.2. to 14.5.

Insert new paragraphs 14.6. to 14.7., to read:

"14.6. Every visor placed on the market with a protective helmet shall be accompanied by information in the national language, or in

at least one of the national languages, of the country of destination. This information shall contain:

- 14.6.1. General instruction for storage and care.
- 14.6.2. Specific instructions for cleaning and their notice of use. These instructions shall include a warning regarding the dangers of using unsuitable agents for cleaning (such as solvents), especially if abrasion resistant coatings are to be preserved.
- 14.6.3. Advice as to the suitability of the visor for use in conditions of poor visibility and during the hours of darkness. The following warning shall be included:
  - 14.6.3.1. Visors with the marking indicating "daytime use only" are not suitable for use during the hours of darkness or in conditions of poor visibility.
- 14.6.4. If appropriate, the following warning shall also be included:
  - 14.6.4.1. The fastening of this visor is such that it will not be possible to remove it instantly from the line of sight with one hand should an emergency (such as headlamp glare or misting) occur.
- 14.6.5. If the visor is MIST RETARDANT approved it may be indicated.
- 14.6.6. Instructions regarding the detection of obsolescence.
- 14.7. Every visor placed on the market as a separate technical unit shall be accompanied by information in the national language, or in at least one of the national languages, of the country of destination. This information shall contain advice on the protective helmets for which the visor is suitable and information on those aspects specified in paragraphs 13.6.1. to 13.6.6. where such information is different to that which accompanied the visor that was placed on the market with the protective helmets for which the visor is stated to be suitable."

Paragraph 14. (former), renumber as paragraph 16.

Paragraphs 15. to 15.3.1. (former), shall be deleted.

Insert new paragraphs 15. to 15.1.5., to read:

- "15. TRANSITIONAL PROVISIONS
- 15.1. Helmets and visors
- 15.1.1. As from the official date of entry into force of the 05 series of amendments, no Contracting Party applying this Regulation shall refuse to grant ECE approval under this Regulation as amended by the 05 series of amendments.

- 15.1.2. As from 18 months after the official date of entry into force of the 05 series of amendments, no Contracting Party applying this Regulation shall grant ECE approvals and extension unless the helmet or visor type to be approved meets the requirements of this Regulation as amended by the 05 series of amendments.
- 15.1.3. As from 30 months after the official date of entry into force of the 05 series of amendments, all the Contracting Parties applying this Regulation shall prohibit the application of approval marks on helmets and visors if they refer to type approvals granted under the preceding series of amendments to this Regulation.
- 15.1.4. As from 36 months after the official date of entry into force of the 05 series of amendments, Contracting Parties applying this Regulation may prohibit the sale of helmets and visors which do not meet the requirements of the 05 series of amendments to this Regulation."
- 15.1.5. From the day of entry into force of this Regulation for the United Kingdom,
- (a) by way of derogation to the obligations of Contracting Parties during the transitional period set out in paragraphs 15.1.1. to 15.1.4., and
  - (b) based on the declaration made by the European Community at the time of its accession to the 1958 Agreement (Depositary Notification C.N.60.1998.TREATIES-28),
- the United Kingdom may prohibit the placing on the market of helmets and visors which do not meet the requirements of the 05 series of amendments to this Regulation."

Annex 1A,

Insert a new item 9., to read

- "9. Helmet without lower face cover (J) / with protective lower face cover (P) / with non protective lower face cover (NP)"

Items 9. to 20. (former), renumber as items 10. to 21.

Annex 2A

Part I. PROTECTIVE HELMET, in the example of the approval mark, amend the approval number "042439-41628" \*/ to read "J-051406-1952". In addition, the caption below, amend to read:

"The above approval mark affixed to a protective helmet shows that the helmet type concerned has been approved in the

Netherlands (E4) under approval number J-051406. The approval number shows that approval concerns a helmet which does not have a lower face cover (J) and was granted in accordance with the requirements of the Regulation already incorporating the 05 series of amendments at the time of approval, and that its production serial number is 1952.

Note: The approval number and the production serial number ..."

Annex 2B

In the example of the approval mark and in the caption below, amend the approval number "045413" \*/ to read "055413" (twice) and the words "04 series of amendments" \*/ to read "05 series of amendments."

---

\*/ An amendment to this provision was omitted in the 04 series of amendments.

Annex 8

Figure 1, renumber as Figure 1a

Insert news Figures 1b and 1c, to read:

"

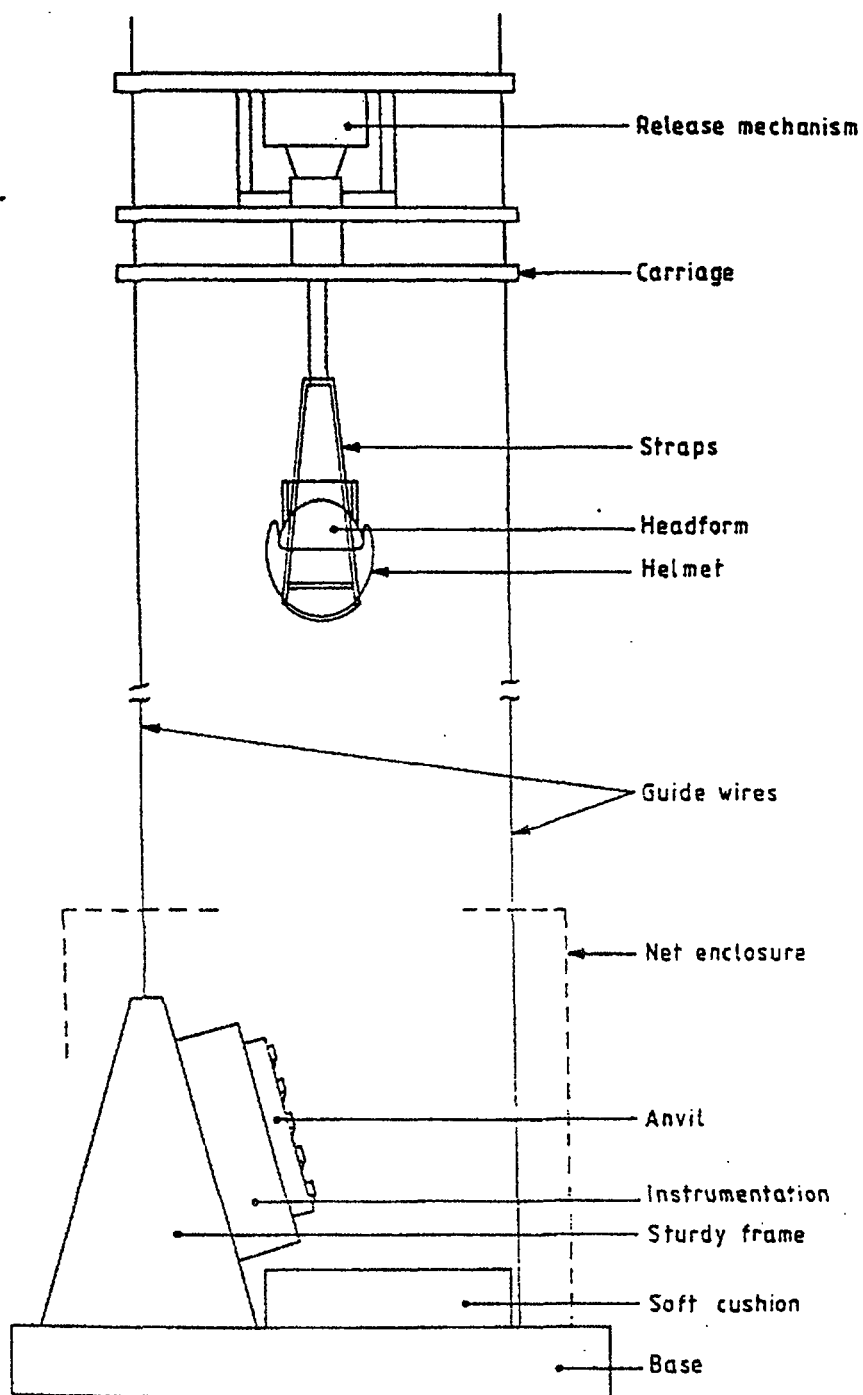

Figure 1b:

Example of a suitable test apparatus for projections and surface friction (method A)

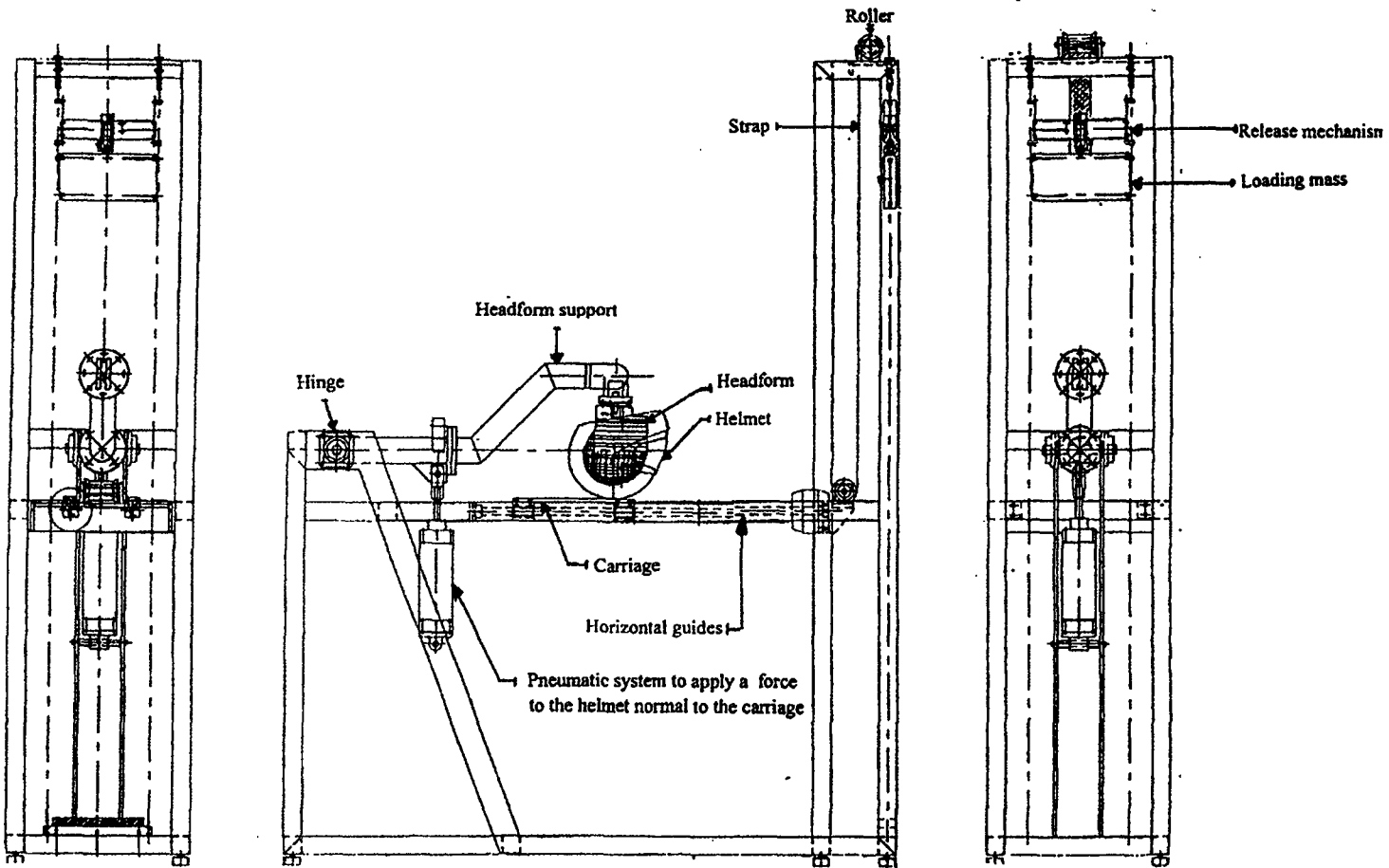

Figure 1c: Example of a suitable test apparatus for projections and surface friction (method B) "

Annex 11

METHOD (b) Figure 1 - Test equipment. delete the word "R = Receiver" and insert a new definition:

"M = silicon detector corrected according to curve V ( $\lambda$ ) with diffusing screen"

Insert new paragraphs 3. to 3.2.2. and figure 3, to read:

"3. METHOD (c)

3.1. Equipment

The test arrangement is shown in figure 3.

Note 1: The measurement principle is identical to the method (a), but the diameter of the measuring is smaller (approximately 2.5 mm) and the test arrangement is simplified.

The beam of the Laser (L) is expanded using the two lenses  $L_1$  and  $L_2$  and is directed towards the measuring point of the ocular (P). Ocular (P) is positioned in such a way what it can rotate around the axis of the beam.

The deviation of the beam is a function of the prismatic refractive power at the measuring point.

The annular or circular diaphragm, whichever is chosen, is at a distance of  $(400 \pm 2)$  mm from the centre of the ocular. The lens A then produces the image of the centre of the ocular on the photoreceptor S.

The part of the test arrangement, comprising the diaphragms, the lens and the receptor is designed to rotate about the vertical axis through the centre of the ocular.

The ocular and the detector part of the apparatus has to pivot in order to compensate for any prismatic refractive power of the ocular.

Note 2: For oculars without corrective effect, it is not necessary, in most cases, for the ocular and the detector part to pivot.

3.2. Procedure

3.2.1. Calibration of the apparatus

Set up the apparatus, the essential features of which are shown in figure 3, without the ocular in place. Put the annular diaphragm  $B_r$  in place. Rotate the detector part of the

apparatus (consisting of a photoreceptor S, a lens A and the annular diaphragm  $B_R$ ) horizontally about P so as to align the light beam from the beam expander (consisting of a lens  $L_1$ , with a typical focal length of 10 mm, a lens  $L_2$  with a typical focal length of 30 mm and a circular diaphragm B with a pinhole of sufficient size so as to provide a uniform beam) with the centre of the annular diaphragm  $B_R$ . Measure the flux  $\phi_{1R}$  falling onto the photoreceptor S, corresponding to the total non-diffused light. Replaced the annular diaphragm  $B_R$  by the circular diaphragm  $B_L$ .

Measure the flux  $\phi_{1L}$  falling onto the photoreceptor, corresponding to the total non-diffused light.

Obtain the reduced luminance factor for the apparatus,  $I_a^*$ , for the solid angle  $\omega$  using the following equation:

$$I_a^* = \frac{1}{\omega} \cdot \frac{\phi_{1R}}{\phi_{1L}}$$

where  $\phi_{1R}$  is the luminous flux without the visor in the parallel beam and with the annular diaphragm  $B_R$  in place

$\phi_{1L}$  is the luminous flux without the visor in the parallel beam and with circular diaphragm  $B_L$  in place

$\omega$  is the solid angle defined by the annular diaphragm  $B_R$

### 3.2.2. Testing of the visor

Place the visor in the parallel beam at position P as shown in figure 3. Repeat paragraph 3.2.1. with the visor in place, and with the visor rotated about the axis of the beam to a position such that the prismatic deviation by the visor is horizontal. Rotate the detector part of the apparatus so that the light beam falls on the centre of  $B_R$ . Obtain the reduced luminance factor for the apparatus including the visor,  $I_g^*$ , for the solid angle  $\omega$  using the following equation:

$$I_g^* = \frac{1}{\omega} \cdot \frac{\phi_{2R}}{\phi_{2L}}$$

where  $\phi_{2R}$  is the luminous flux with the visor in the parallel beam and with the annular diaphragm  $B_R$  in place



$\phi_{2L}$  is the luminous flux without the visor in the parallel beam and with circular diaphragm  $B_L$  in place

$\omega$  is the solid angle defined by the annular diaphragm  $B_R$

Then calculate the reduced luminance factor  $I^*$  of the ocular using the following equation:

$$I^* = I_g^* - I_a^*$$

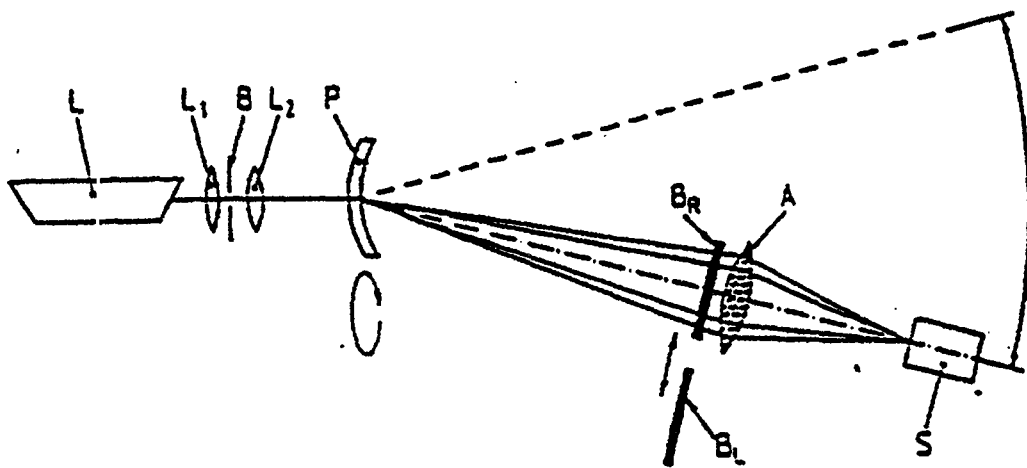

**Figure 3:** Arrangement of Apparatus for Measurement of Light Diffusion - Method (c)

- L = Laser with wavelength of  $(600 \pm 70)$  nm.  
Note: Class 2 laser recommended.  
< 1mW. Diameter of beam between 0.6 and 1 mm
- $L_1$  = 10 mm nominal focal length lens
- $L_2$  = 30 mm nominal focal length lens
- B = Circular diaphragm - (a hole of 0.1 mm approx produces a uniform light beam)
- P = Visor sample
- $B_R$  = Annular diaphragm, the diameter of the external circle being  $(28.0 \pm 0.1)$  mm and the inner circle  $(21.0 \pm 0.1)$  mm. See Note 2 below.
- $B_L$  = Circular diaphragm of 10 mm nominal diameter
- A = Lens, 200 mm nominal focal length and 30 mm nominal diameter
- S = Photoreceptor

The distance between the annular/circular diaphragm and the centre of the ocular shall be  $(400 \pm 2)$  mm.

Note 1: The focal lengths of the lenses are only given as a guide. Other focal lengths may be used, for example, if a wider beam is desired or a smaller image of the sample is to be formed on the receptor.

Note 2: The diameters of the annular diaphragm circles shall be measured to an uncertainty not exceeding 0.01 mm in order that the solid angle  $\omega$  may be determined accurately; any deviation from the nominal diameters shall be taken into account by calculation."

Insert new annexes 12 to 16, to read:

"Annex 12

Type approval scheme (Flow chart)

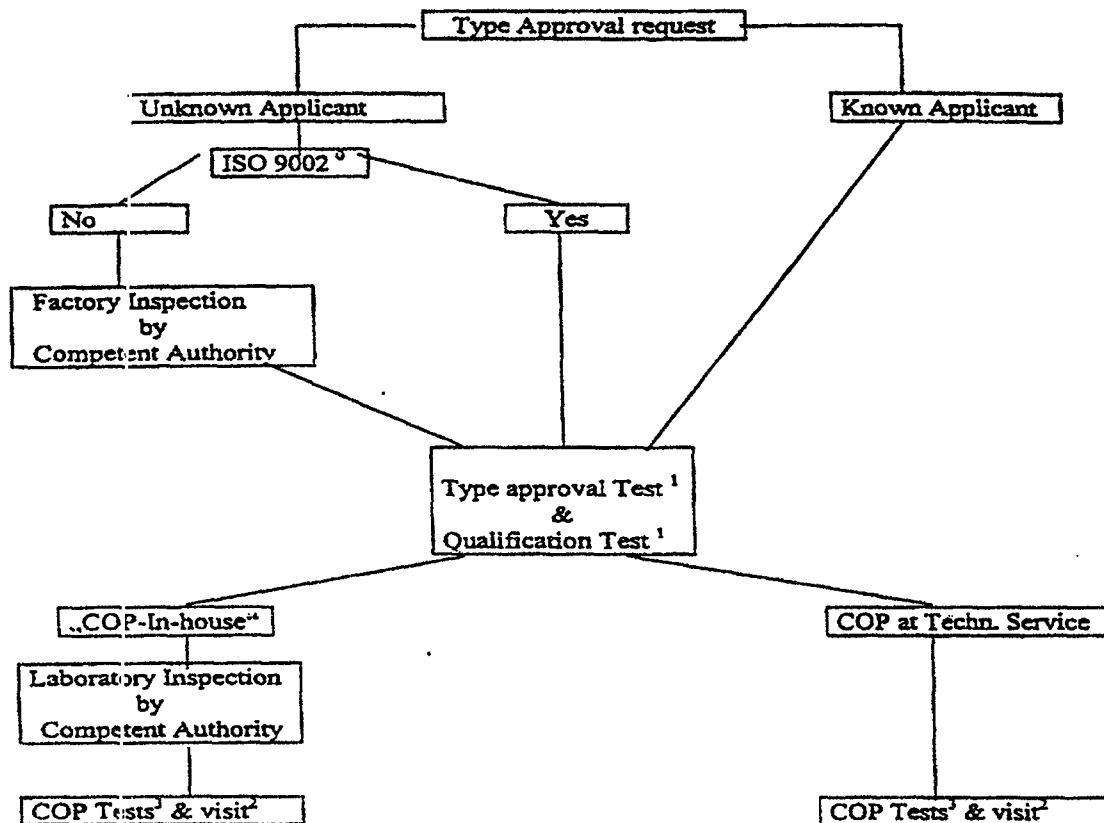

- 0) or an equivalent standard to this one
- 1) this tests have to be done at technical service
- 2) Visit of the manufacturer for inspection and random sampling by the authority or technical service:
  - a) if there is no ISO 9002: 3 times a year
  - b) if there is an ISO 9002: 1 time a year
- 3) tests in accordance to 10.5 and/ or 10.6 on samples taken out of the production:
  - a) if there is no ISO 9002: of the authority or technical service during the visit of footnote 2 a of the manufacturer between the visits of footnote 2 a
  - b) if there is an ISO 9002: taken by the manufacturer, procedure checked during visit of footnote 2 b

Annex 13

The luminous transmittance  $\tau_v$  is defined as:

$$\tau_v = \frac{\int_{380nm}^{780nm} S_{D65\lambda}(\lambda) \cdot V(\lambda) \cdot \tau_F(\lambda) \cdot d\lambda}{\int_{380nm}^{780nm} S_{D65\lambda}(\lambda) \cdot V(\lambda) \cdot d\lambda}$$

The relative visual attenuation quotient Q is defined as:

$$Q = \frac{\tau_{sign}}{\tau_v}$$

where:

$\tau_v$  is the luminous transmittance of the visor relative to the standard illuminant D65

$\tau_{sign}$  is the luminous transmittance of the visor relative to the spectral power distribution of the traffic signal light

$\tau_{sign}$  is given by the equation:

$$\tau_{sign} = \frac{\int_{380nm}^{780nm} S_{A\lambda}(\lambda) \cdot V(\lambda) \cdot \tau_F(\lambda) \cdot \tau_S(\lambda) \cdot d\lambda}{\int_{380nm}^{780nm} S_{A\lambda}(\lambda) \cdot V(\lambda) \cdot \tau_S(\lambda) \cdot d\lambda}$$

where:

$S_{A\lambda}(\lambda)$  is the spectral distribution of radiation of CIE standard illuminant A (or 3200 K light source for blue signal light). See: ISO/CIE 10526, "CIE standard colorimetric illuminants";

$S_{D65\lambda}(\lambda)$  is the spectral distribution of radiation of CIE standard illuminant D65. See: ISO/CIE 10526, "CIE standard colorimetric illuminants";

$V(\lambda)$  is the spectral visibility function for daylight vision. See: ISO/CIE 10527, "CIE standard colorimetric observers";

$\tau_s(\lambda)$  is the spectral transmittance of the traffic signal lens;

$\tau_v(\lambda)$  is the spectral transmittance of the visor.

The spectral value of the product of the spectral distributions ( $S_{\lambda\lambda}(\lambda) \cdot S_{D65\lambda}(\lambda)$ ) of the illuminant, the spectral visibility function  $V(\lambda)$  of the eye and the spectral transmittance  $\tau_s(\lambda)$  of the traffic signal lenses are given in annex B.

Annex 14

PRODUCTS OF THE SPECTRAL DISTRIBUTION OF RADIATION OF THE SIGNAL LIGHTS  
AND STANDARD ILLUMINANT D65 AS SPECIFIED IN ISO/CIE 10526 AND THE SPECTRAL  
VISIBILITY FUNCTION OF THE AVERAGE HUMAN EYE FOR DAYLIGHT VISION  
AS SPECIFIED IN ISO/CIE 10527.

Table 14.1

Wavelength nm	$S_{\lambda\lambda}(\lambda) \cdot V(\lambda) \cdot \tau_s(\lambda)$				$S_{D65\lambda}(\lambda) \cdot V(\lambda)$
	red	yellow	green	blue	
380	0	0	0	0,0001	0
390	0	0	0	0,0008	0,0005
400	0	0	0,0014	0,0042	0,0031
410	0	0	0,0047	0,0194	0,0104
420	0	0	0,0171	0,0887	0,0354
430	0	0	0,0569	0,3528	0,0952
440	0	0	0,1284	0,8671	0,2283
450	0	0	0,2522	1,5961	0,4207
460	0	0	0,4852	2,6380	0,6888
470	0	0	0,9021	4,0405	0,9894
480	0	0	1,6718	5,9025	1,5245
490	0	0	2,9976	7,8852	2,1415
500	0	0	5,3553	10,1566	3,3438
510	0	0	9,0832	13,0560	5,1311
520	0	0,1817	13,0180	12,8363	7,0412
530	0	0,9515	14,9085	9,6637	8,7851
540	0	3,2794	14,7624	7,2061	9,4248

550	0	7,5187	12,4687	5,7806	9,7922
560	0	10,7342	9,4061	3,2543	9,4156
570	0	12,0536	6,3281	1,3975	8,6754
580	0,4289	12,2634	3,8967	0,8489	7,8870
590	6,6289	11,6601	2,1640	1,0155	6,3540
600	18,2382	10,5217	1,1276	1,0020	5,3740
610	20,3826	8,9654	0,6194	0,6396	4,2648
620	17,6544	7,2549	0,2965	0,3253	3,1619
630	13,2919	5,3532	0,0481	0,3358	2,0889
640	9,3843	3,7352	0	0,9685	1,3861
650	6,0698	2,4064	0	2,2454	0,8100
660	3,6464	1,4418	0	1,3599	0,4020
670	2,0058	6,7692	0	0,6308	0,2492
680	1,1149	0,4376	0	1,2166	0,1260
690	0,5590	0,2191	0	1,1493	0,0541
700	0,2902	0,1137	0	0,7120	0,0278
710	0,1533	0,0601	0	0,3918	0,0148
720	0,0742	0,0290	0	1,2056	0,0058
730	0,0386	0,0152	0	0,1049	0,0033
740	0,0232	0,0089	0	0,0518	0,0014
750	0,0077	0,0030	0	0,0254	0,0006
760	0,0046	0,0017	0	0,0129	0,0004
770	0,0022	0,0009	0	0,0065	0
780	0,0010	0,0004	0	0,0033	0
Sum	100	100	100	100	100

Annex 15

TEST OF REFRACTIVE POWERS

1. Spherical and astigmatic refractive powers

1.1. Apparatus

1.1.1. Telescope

A telescope with an aperture nominally 20 mm and a magnification between 10 and 30, fitted with an adjustable eyepiece incorporating a reticular.

1.1.2. Illuminated target

A target, consisting of a black plate incorporating the cut-out pattern shown in figure 1, behind which is located a light source of adjustable luminance with a condenser, if necessary, to focus the magnified image of the light source on the telescope objective.

The large annulus of the target has an outer diameter of  $(23 \pm 0.1)$  mm with an annular aperture of  $(0.6 \pm 0.1)$  mm. The small annulus has a inner diameter of  $(11.0 \pm 0.1)$  mm with annular aperture of  $(0.6 \pm 0.1)$  mm. The central aperture has a diameter of  $(0.6 \pm 0.1)$  mm. The bars are nominally 20 mm long and 2 mm wide with a nominal 2 mm separation.

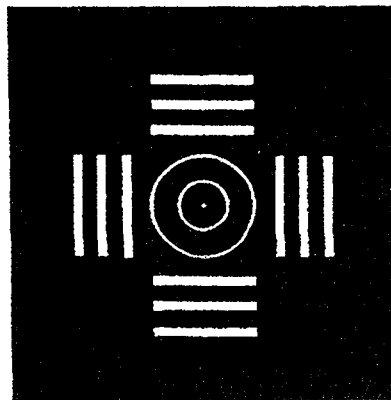

Figure 1: Telescope target

1.1.3. Filter

A filter with its maximum transmittance in the green part of the spectrum may be used to reduce chromatic aberrations.

#### 1.1.4. Calibration lenses

Lenses with positive and negative spherical refractive powers of 0.06 m<sup>-1</sup>, 0.12 m<sup>-1</sup> and 0.25 m<sup>-1</sup> (tolerance  $\pm$  0.01 m<sup>-1</sup>).

#### 1.2. Arrangement and calibration of apparatus

The telescope and illuminated target are placed on the same optical axis (4.60  $\pm$  0.02) m apart.

The observer focuses the reticule and the target and aligns the telescope to obtain a clear image of the pattern. This setting is regarded as the zero point of the focusing scale of the telescope.

The focusing adjustment of the telescope is calibrated with the calibration lenses (paragraph 1.2.4.) so that a power of 0.01 m<sup>-1</sup> may be measured. Any other calibration method may be used.

#### 1.3. Procedure

The visor is mounted in front of the telescope as worn and measurements shall be taken at the sign points as specified in paragraph 6.15.3.8.

##### 1.3.1. Spherical and astigmatic refractive powers

###### 1.3.1.1. Visors without astigmatic refractive power

The telescope is adjusted until the image of the target is perfectly resolved.

The spherical power of the visor is then read from the scale of the telescope.

###### 1.3.1.2. Visor with astigmatic refractive power

The target, on the visor, is rotated in order to align the principal meridians of the visor with the bars on the target. The telescope is focused firstly on one set of bars (measurement D1) and then on the perpendicular bars (measurement D2). The spherical

power is the mean,  $\frac{D_1 + D_2}{2}$ , the astigmatic refractive power is the absolute difference,  $| D_1 - D_2 |$ , of the two measurements.

#### 2. Determination of the difference in prismatic refractive power

##### 2.1. Apparatus

The arrangement of the reference method is shown in figure 2.



2.2.1. Procedure

The diaphragm LB1, illuminated by the light source, is adjusted in such a way that it produces an image on the plane B when the visor (P) is not in position. The visor is placed in front of the lens L2 so that the axis of the visor is parallel to the optical axis of the test assembly.

Adjustable tilt visors are positioned with their ocular regions normal to the optical axis of the equipment.

Measure the vertical and horizontal distance between the two displaced images arising from the two ocular areas of the visor.

These distance in cm are divided by 2 to give the horizontal and vertical prismatic difference in cm/m.

If the light paths which correspond to the two eye regions cross, the prismatic refractive power is 'base in' and if the light paths do not cross, it is 'base out'.

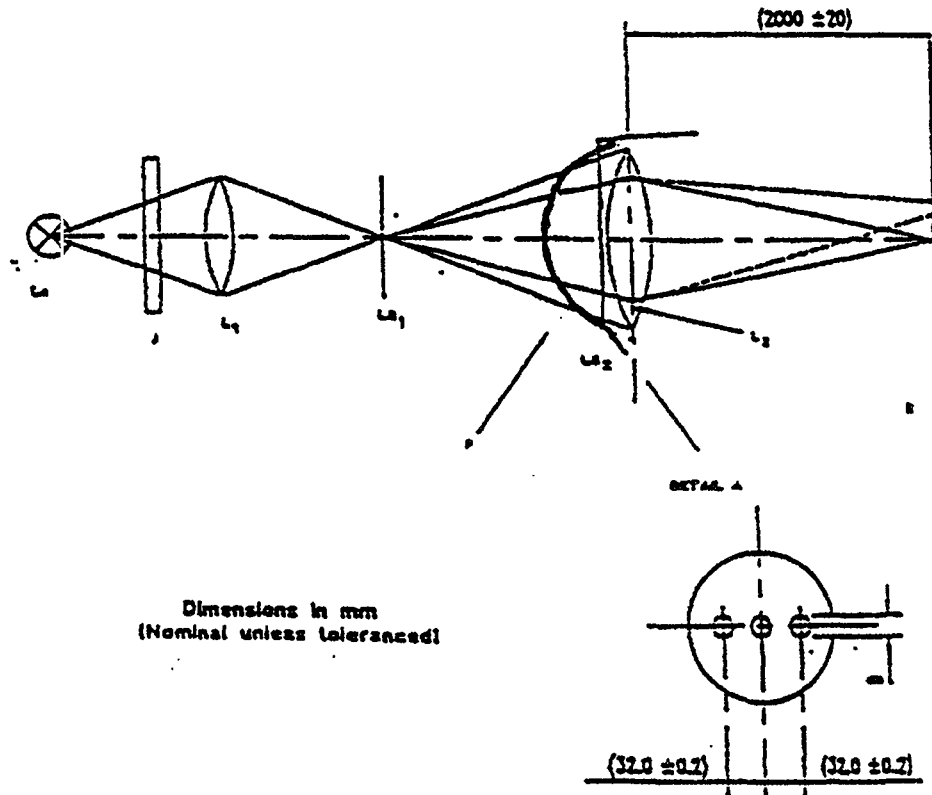

Figure 2: Arrangement apparatus for measurement of prismatic difference

- $L_a$  = light source, for example, small filaments lamp, laser with wavelength of  $(600 \pm 70)$  nm, etc.
- $J$  = interface filter, with peak transmittance in the green part of the spectrum (required only if a filament lamp is used as the light source).
- $L_1$  = achromatic lens focal length between 20 and 50 mm.
- $LB_1$  = diaphragm, diameter of aperture 1 mm nominal
- $P$  = visor
- $LB_2$  = diaphragm as shown in detail A
- $L_2$  = achromatic lens, 1000 mm nominal focal length and 75 mm nominal diameter
- $B$  = image plane

---

Annex 16

TEST FOR MIST-RETARDANT VISOR

1. Apparatus

Apparatus to determine the change in the non - diffused transmittance value, as shown in figure 1.

The nominal diameter of the parallel beam is 10 mm. The size of the beam divider, reflector R and lens  $L_3$  shall be selected in such a way that diffused light is captured up to an angle of  $0.75^\circ$ . If a lens  $L_3$  with a nominal focal length  $f_3 = 400$  mm is used, the nominal diameter of a diaphragm is 10 mm. The plane of the diaphragm must lie within the focal plane of the lens  $L_3$ .

The following focal lengths  $f_i$  of the lens  $L_1$  are nominal examples and will not effect the test results:

$$f_1 = 10 \text{ mm and } f_2 = 100 \text{ mm}$$

The light source shall be a laser with a wavelength of  $(600 \pm 70)$  nm.

The volume of air above the water bath is at least 4 litres. The seating ring has a nominal diameter of 35 mm and a nominal height of 24 mm is then measured to the highest point of the seating ring. A soft rubber ring, 3 mm thick and 3 mm wide (nominal dimensions), is inserted between the sample and the seating ring.

The water bath container also contains a ventilator to circulate the air. In addition, there must also be a device to stabilise the temperature on the water bath.

2. Samples

At least 3 samples of the same type are to be tested. Before the test, the samples are conditioned for one hour in distilled water (at least 5 cm<sup>3</sup> water per cm<sup>2</sup> sample surface area) at (23 ± 5)°C, then dabbed dry and then conditioned in air for at least 12 hours at (23 ± 5)°C and 50 per cent nominal relative humidity.

3. Procedure and evaluation

The ambient temperature during the measurement is (23 ± 5)°C.

The temperature of the water bath is set at (50 ± 0.5)°C. The air above the water bath is circulated using a ventilator, so that it becomes saturated with water vapour. During this time, the measurement opening is to be covered. The ventilator is switched off before the measurement.

To measure the change in the value of the transmittance  $\tau_r$ , the sample is placed on the seating ring and the time determined until the square of  $\tau_r$  has dropped to less than 80% of the initial value of the sample without fogging (time without fogging).

$$\tau_r^2 = \frac{\phi b}{\phi u}$$

where:

$\phi b$  is the luminous flux when there is fogging on the sample

$\phi u$  is the luminous flux before fogging

Initial fogging of maximum 0.5 s duration shall not be taken into consideration in the evaluation.

Note 1: Since the light beam passes through the samples twice, this measurement defines  $\tau_r^2$ .

Note 2: The period until the start of the fogging can usually be determined visually. However, with some types of coating the formulation of the surface water causes diffusion to increase more slowly so that visual evaluation is difficult. The detection apparatus described in paragraph 1.1. should then be used.

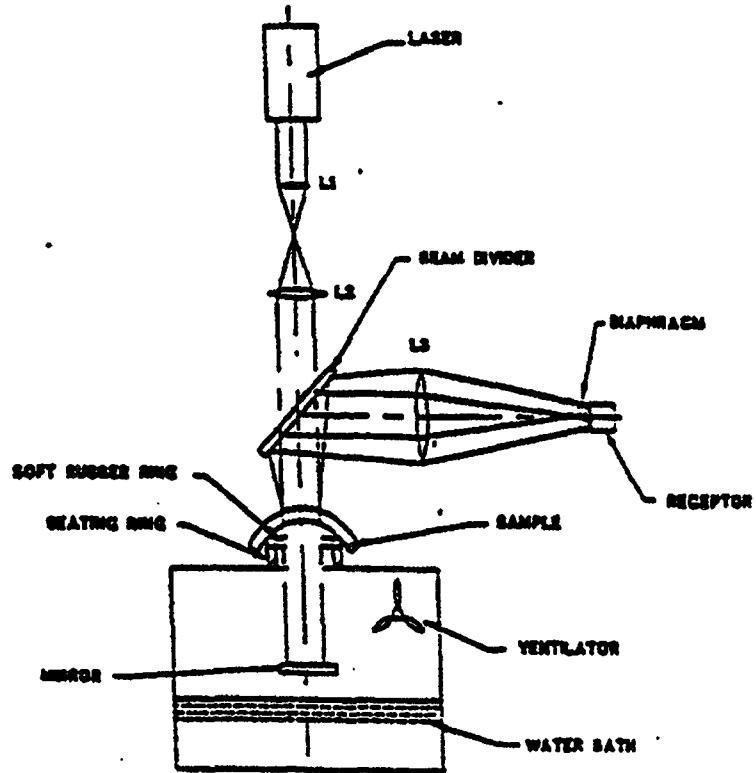

Figure 1: Test's apparatus for mist-retardant visor"

UNITED NATIONS  NATIONS UNIES

POSTAL ADDRESS—ADRESSE POSTALE: UNITED NATIONS, N.Y. 10017  
CABLE ADDRESS—ADRESSE TELEGRAPHIQUE: UNATIONS NEWYORK

Référence : C.N.1188.1999.TREATIES-4 (Notification Dépositaire)

ACCORD CONCERNANT L'ADOPTION DE CONDITIONS UNIFORMES  
D'HOMOLOGATION ET LA RECONNAISSANCE RÉCIPROQUE DE  
L'HOMOLOGATION DES ÉQUIPEMENTS ET PIÈCES DE VÉHICULES À  
MOTEUR. GENÈVE, 20 MARS 1958

RÈGLEMENT NO 22. PRESCRIPTIONS UNIFORMES RELATIVES À  
L'HOMOLOGATION DES CASQUES DE PROTECTION ET DE LEURS  
ÉCRANS POUR CONDUCTEURS ET PASSAGERS DE MOTOCYCLES ET DE  
CYCLOMOTEURS

PROPOSITION D'AMENDEMENTS AU RÈGLEMENT

Le 22 décembre 1999, le Secrétaire général a reçu du Comité administratif de l'Accord susmentionné, conformément au premier paragraphe de l'article 12 de l'Accord, certains amendements proposés au Règlement No. 22.

.....  
On trouvera ci-joint un exemplaire du document, en langues anglaise et française, contenant le texte du projet d'amendements (TRANS/WP.29/694).

A cet égard, le Secrétaire général croit bon de rappeler les deuxième et troisième paragraphes de l'article 12 de l'Accord, qui stipulent :

"2. Un amendement à un règlement est réputé adopté si, dans un délai de six mois à compter de la date où le Secrétaire général en a donné notification, plus d'un tiers des Parties contractantes appliquant le règlement à la date de la notification n'ont pas notifié au Secrétaire général leur désaccord concernant l'amendement. Si à l'issue de cette période plus d'un tiers des Parties contractantes appliquant le règlement n'ont pas notifié au Secrétaire général leur désaccord, celui-ci déclare le plus tôt possible que l'amendement est adopté et obligatoire pour les Parties contractantes appliquant le règlement qui n'ont pas contesté l'amendement. Si un règlement fait l'objet d'un amendement et si au moins un cinquième des Parties contractantes qui en appliquent la version non amendée déclarent ultérieurement qu'elles souhaitent continuer de l'appliquer, cette version non amendée est considérée comme une variante de la version amendée et est incorporée formellement à ce titre dans le règlement avec prise d'effet à la date de l'adoption de l'amendement ou de son entrée en vigueur. Dans ce cas, les obligations des Parties contractantes appliquant le règlement sont les mêmes que celles énoncées au paragraphe 1.

3. Au cas où un pays serait devenu Partie à cet Accord entre la notification de l'amendement à un règlement adressée au Secrétaire général et l'entrée en vigueur de l'amendement, le règlement en cause ne pourrait entrer en vigueur à l'égard de cette Partie contractante que deux mois après qu'elle

Attention : Services des Traités des Ministères des Affaires Étrangères et organisations internationales concernés.

cause ne pourrait entrer en vigueur à l'égard de cette Partie contractante que deux mois après qu'elle aurait accepté formellement l'amendement ou qu'un délai de six mois se serait écoulé depuis la communication que le Secrétaire général lui aurait faite du projet d'amendement."

Le 30 décembre 1999

A handwritten signature in black ink, appearing to be a stylized monogram or initials.